

INSTALLATION AND OPERATION MANUAL

code 80960D - 05-2014 - ENG



INDEX

1 Preliminary instructions	2	3.3	Connections input/output GTF 150-250A
1.1 Profile		3.4	Functions of indicator leds
1.2 General description		3.5	Control connectors
1.3 Preliminary instructions		3.6	Configuration TTL port (GTF standars)
2 Installation and Connection	4	3.7	Serial communication port Modbus RS485 (option)
2.1 Electrical power supply		3.8	Connection example: communication ports
2.2 Notes on electrical safety and electromagnetic compatibility		3.9	Connection example: power section
2.3 Recommendations for correct installation for purposes of EMC		3.10	Digital input (PWM)
2.4 Dimensions		4 Installation of serial network	31
2.5 Installation		4.1	“AUTOBAUD SERIAL” sequence
2.6 General description GTF 25-120A		5 Technical Characteristics	33
2.7 General description GTF 150-250A		5.1	Derating Curves GTF
2.8 Cleaning/checking or replacing the fan for GTF 150-250A		6 Technical-Commercial information	36
2.9 Substitution of Internal Fuse (Option only for GTF 150-250A)		6.1	Accessories
3 Electrical connections	12	6.2	Fuses / Fuseholders
3.1 Power connections			
3.2 Connections input/output 25-120A			

GRAPHIC SYMBOLS

To differentiate the type and importance of the information in this User Manual, graphic reference symbols are used to make such information easier to interpret.



Indicates contents of sections, general instructions, notes, and other points to which the reader's attention needs to be called.



Indicates a suggestion based on the experience of GEFRAN's Technical Personnel that could be especially useful under certain circumstances.



Indicates a particularly delicate situation that could affect the safety or correct operation of the controller, or an instruction that **MUST** be followed to prevent hazards.



Indicates a reference to Detailed Technical Documents available on the GEFRAN website www.gefran.com.



Indicates a risk to the user's safety due to high voltage at the points indicated.

1 • PRELIMINARY INSTRUCTIONS

1.1 PROFILE

The “GTF” series of microprocessor advanced solid state power units controls, in compact and optimized size, high electric powers with different types of heating elements, single-phase, biphas or triphase.

Current levels range from 40A to 250A, nominal voltage from 480 VAC to 600VAC.

The command input is configurable and accepts 0-10V, 0/4-20mA signals, potentiometer, logic signals, including with PWM modes for cost effective solutions.

The device can also be operated via Modbus RTU serial communication, with IN/OUT chain connections facilitated by plug-in RJ10 (telephone) connectors.

The several trigger modes are software configurable and provide:

- **ZC:** Zero Crossing constant cycle time (settable in range 1-200sec), for conventional loads
- **BF:** Burst-Firing, Zero crossing with optimized minimum cycle time, for systems with low thermal inertia, medium-wave IR lamps
- **HSC:** Half Single Cycle Zero Crossing corresponds to Burst Firing that manages single semi-cycles of conduction or stop cycles, useful for short-wave IR lamps, reduces flickering and limits generation of EMC noise on the power line (applied only to single-phase load or open delta).
- **PA:** Phase angle control, useful for short-wave IR lamps, transformer primaries. Completely eliminates flickering of load filaments, but generates EMC noise on power line (harmonics).

Soft Start and soft stop ramp functions can be assigned to these controls with limitation of current peaks and/or maximum RMS current level.

Thanks to sophisticated Hardware and Software solutions, you can precisely control different types of loads.

Phase angle control (the only control method that completely eliminates IR lamp flickering), matched with current, voltage, or load power feedback functions, allows the easy use of “critical” applications such as (for example), special resistors such as special Super Khantal™ heating elements, Silicon Carbide resistors, or transformer primaries either single-phase or triphase.

GTF runs complete diagnostics of current, voltage, power, and temperature levels:

Current Diagnostics:

- Total and partial load interrupt alarm
- Self-learn function of alarm limit for interrupted load
- Alarm for SCR in short circuit
- Alarm for load in short circuit or overcurrent

Voltage Diagnostics:

- Alarm for absence of phase

Temperature Diagnostics:

- Alarm for over temperature of power module

Power control with Soft start ramp limits load, optimizes the consumptions and increases the load operating duration.

Device parameters can be configured from PC, by means of a simple configuration SW which lets you save all parameters in a configuration file that is easy to manage and to copy to other devices. Moreover, an RS485 serial connection of GTF is offered with Modbus RTU protocol to control currents, voltages, powers, load status, and device status from the supervisor terminal (HMI) or PLC.



The section contains general information and warnings to be read before installing, configuring and using the controller.

1.2 GENERAL DESCRIPTION

GTF is single-zone advanced solid state power unit, extremely compact, equipped with different optional functions; it offers an exclusive combination of performance, reliability, and flexibility. In particular, this new line of Gefran controllers is the ideal solution for sectors demanding high performance and continuity of service, such as:

- Thermoforming
- Blowing
- Hot runners for injection presses
- Texturizing of fibers
- Heat treatment furnaces
- Woodworking machines
- Glass tempering furnaces

The modules series GTF controllers are based on an extremely versatile hardware and software platform, with options to select the best I/O configuration for your system.

GTF is used for the power control of single-phase and 2-phase loads, including resistive loads with high and low temperature coefficient, short wave IR lamps, or transformer primaries.



Attention: the description of programming and configuration parameters are contained in the “Programming and configuration” manual, downloadable from the website www.gefran.com

1.3 PRELIMINARY INSTRUCTION

Read the following preliminary instructions before installing and using the GTF modular power controller. This will make start-up faster and avoid some problems that could be mistakenly interpreted as malfunctions or limitations of the controller.



Immediately after unpacking the unit, check the order code and the other data on the label attached to the outside of the container.

Write them on the following table.

This data must always be available and given to Gefran Customer Care representatives are available if technical service is needed.

SN.....	(Serial number)
CODE	(Product code)
TYPE.....	(Order code)
SUPPLY.....	(Power Supply)
VERS.	(Firmware version)

Check that the controller is in perfect condition, was not damaged during shipment, and that the package also contains the “Configuration and Programming” manual.

Immediately report any errors, shortages, or signs of damage to your Gefran dealer.

Check that the order code matches the configuration requested for the intended application by consulting the section: “Technical-Commercial Information.”

Example: GTF 90 - 480 - 0 - 1 - 0 - M

Model	_____	_____	_____	_____	_____	_____
Nominal current	_____	_____	_____	_____	_____	_____
Nominal voltage	_____	_____	_____	_____	_____	_____
Control option, Absent	_____	_____	_____	_____	_____	_____
Diagnostic option: HB	_____	_____	_____	_____	_____	_____
Fuse: absent	_____	_____	_____	_____	_____	_____
Serial Modbus	_____	_____	_____	_____	_____	_____

See paragraph 2.1 “Dimensions and mounting” before installing the GTF on the machine/host system control panel.

To configure the PC use the SW Gefran GF-Express kit and the relative connection cable.

For the order code, see Section: “Technical-Commercial Information”.



Users and/or system integrators who want detailed information on serial communication between Gefran standard and/or industrial PCs and Gefran Programmable Instruments can access Technical Reference Documents on serial communication and MODBus protocol, etc., in Adobe Acrobat format on the Gefran website www.gefran.com:

- Serial Communication
- MODBus Protocol

Before calling Gefran Customer Care in case of assumed malfunctions, please see the Troubleshooting Guide in the “Maintenance” section and, if necessary, the F.A.Q. (Frequently Asked Questions) section on the Gefran website www.gefran.com



This section contains the instructions needed for correct installation of GTF controllers on the machine/host system control panel and for correct connection of the power supply, inputs, outputs and interfaces.



CAREFULLY READ THE FOLLOWING WARNINGS BEFORE INSTALLING THE INSTRUMENT!
Disregard of such warnings could create electrical safety and electromagnetic compatibility problems, as well as void the warranty.

2.1 ELECTRICAL POWER SUPPLY

- the controller DOES NOT have an On/Off switch: the user must install switch/isolator conforming to safety requisites (CE mark) to cut off the power supply up-line of the controller. The switch must be installed in the immediate vicinity of the controller in easy reach of the operator. A single switch can be used for multiple devices.
- the earth connection must be made with a specific lead.
- if the product is used in applications with risk of harm to persons or damage to machines or materials, it MUST be equipped with auxiliary alarm devices. It is advisable to provide the ability to check for tripped alarms during regular operation. DO NOT install the product in rooms with hazardous (inflammable or explosive) atmosphere; it may be connected to elements that operated in such atmosphere only by means of appropriate interfaces that conform to current safety standards.

2.2 NOTES ON ELECTRICAL SAFETY AND ELECTROMAGNETIC COMPATIBILITY:

2.2.1 CE MARKING: EMC (electromagnetic compatibility) conformity

in compliance with Directive 2004/108/CE and following modifications.

Series GTF controllers are mainly intended for industrial use, installed on panels or control panels of production process machines or systems.

For purposes of electromagnetic compatibility, the most restrictive generic standards have been adopted, as shown on the table.

2.2.2 LV (low voltage) conformity

in compliance with Directive 2006/95/CE.



EMC compliance has been verified with respect to the information in Tables 1 and 2.

2.3 RECOMMENDATIONS FOR CORRECT INSTALLATION FOR PURPOSES OF EMC

2.3.1 Instrument power supply

- The power supply for the electronic instrumentation on the panels must always come directly from a cut-off device with fuse for the instrument part.
- Electronic instrumentation and electromechanical power devices such as relays, contactors, solenoids, etc., MUST ALWAYS be powered by separate lines.
- When the power supply line of electronic instruments is heavily disturbed by switching of thyristor power groups or by motors, you should use an isolation transformer only for the controllers, grounding its sheathing.
- It is important for the system to be well-grounded:
 - voltage between neutral and ground must not be > 1V
 - Ohmic resistance must be < 6Ω;
- If the grid voltage is highly unstable, use a voltage stabilizer.
- In proximity of high-frequency generators or arc welders, use adequate grid filters.
- The power supply lines must be separate from instrument input and output lines.



- Supply from Class II or from limited energy source

2.3.2 Input and output connections

Before connecting or disconnecting any connection, always check that the power and control cables are isolated from voltage. Appropriate devices must be provided: fuses or automatic switches to protect power lines. The fuses present in the module function solely as a protection for the GTF semiconductors.

- Connected outside circuits must be doubly isolated.
- To connect analog inputs, strain gauges, linears, (TC, RTD), you have to:
 - physically separate the input cables from those of the power supply, outputs, and power connections.
 - use braided and shielded cables, with sheathing grounded at a single point.

2.3.3 Installation notes

Use the extra-rapid fuse indicated in the catalogue according to the connection example equipped.

- Moreover, the applications with solid-state units require a safety automatic switch to section the load power line. To ensure maximum reliability, the device must be correctly installed in the panel in such a way as to obtain adequate heat exchange between the heat sink and the surrounding air under conditions of natural convection.. Fit the device vertically (maximum angle 10° to the vertical axis) see figure 3
 - Vertical distance between a device and the panel wall >100mm
 - Horizontal distance between a device and the panel wall at last 10mm
 - Vertical distance between a device and the next one at last 300mm.
 - Horizontal distance between a device and the next one at last 10mm.

Check that the cable holder runners do not reduce these distances, in this case fit the cantilever units opposite the panel so that the air can flow vertically on the dissipator without any obstacles.

- dissipation of device thermic power with effects on installation room temperature.
- thermal power dissipation with limits on installation room temperature.
- requires exchange with external air or an air conditioner to transfer dissipated power outside the panel.
- maximum limits of voltage and derived power of transients on the line, for which the solid state power unit contains protective devices (based on the model).

- presence of dispersion current in GTF in non-conducting state (current of a few mA due to RC Snubber circuit to protect the thyristor).



GEFRAN S.p.A. assumes no liability for any damage to persons or property deriving from tampering, from incorrect or improper use, or from any use not conforming to the characteristics of the controller and to the instructions in this User Manual.

Table 1 EMC Emission

AC semiconductor motor controllers and conductors for non-motor loads	EN 60947-4-3	
Emission enclosure compliant in firing mode single cycle and phase angle if external filter fitted	EN 60947-4-3 CISPR-11 EN 55011	Class A Group 2

Table 2 EMC Immunity

Generic standards, immunity standard for industrial environments	EN 60947-4-3	
ESD immunity	EN 61000-4-2	4 kV contact discharge 8 kV air discharge
RF interference immunity	EN 61000-4-3 /A1	10 V/m amplitude modulated 80 MHz-1 GHz 10 V/m amplitude modulated 1.4 GHz-2 GHz
Conducted disturbance immunity	EN 61000-4-6	10 V/m amplitude modulated 0.15 MHz-80 MHz
Burst immunity	EN 61000-4-4	2 kV power line 2 kV I/O signal line
Surge immunity	EN 61000-4-4/5	Power line-line 1 kV Power line-earth 2 kV Signal line-earth 2 kV Signal line-line 1 kV
Magnetic fields immunity	Test are not required. Immunity is demonstrated by the successful completion of the operating capability test	
Voltage dips, short interruptions and voltage immunity tests	EN 61000-4-11	100%U, 70%U, 40%U,

Table 3 LVD Safety

Safety requirements for electrical equipment for measurement, control and laboratory use	EN 61010-1 UL 508	
--	----------------------	--

ATTENTION

This product has been designed for class A equipment. Use of the product in domestic environments may cause radio interference, in which case the user may be required to employ additional mitigation methods.

EMC filters are required in PA mode (Phase Angle, i.e., SCR trigger with phase angle modulation).
The filter model and current level depend on the configuration and load used.
The power filter **MUST** be connected as close as possible to the GTF.
You can use a filter connected between the power line and GTF or an LC group connected between the GTF output and the load.

The CE declaration of conformity is available on request

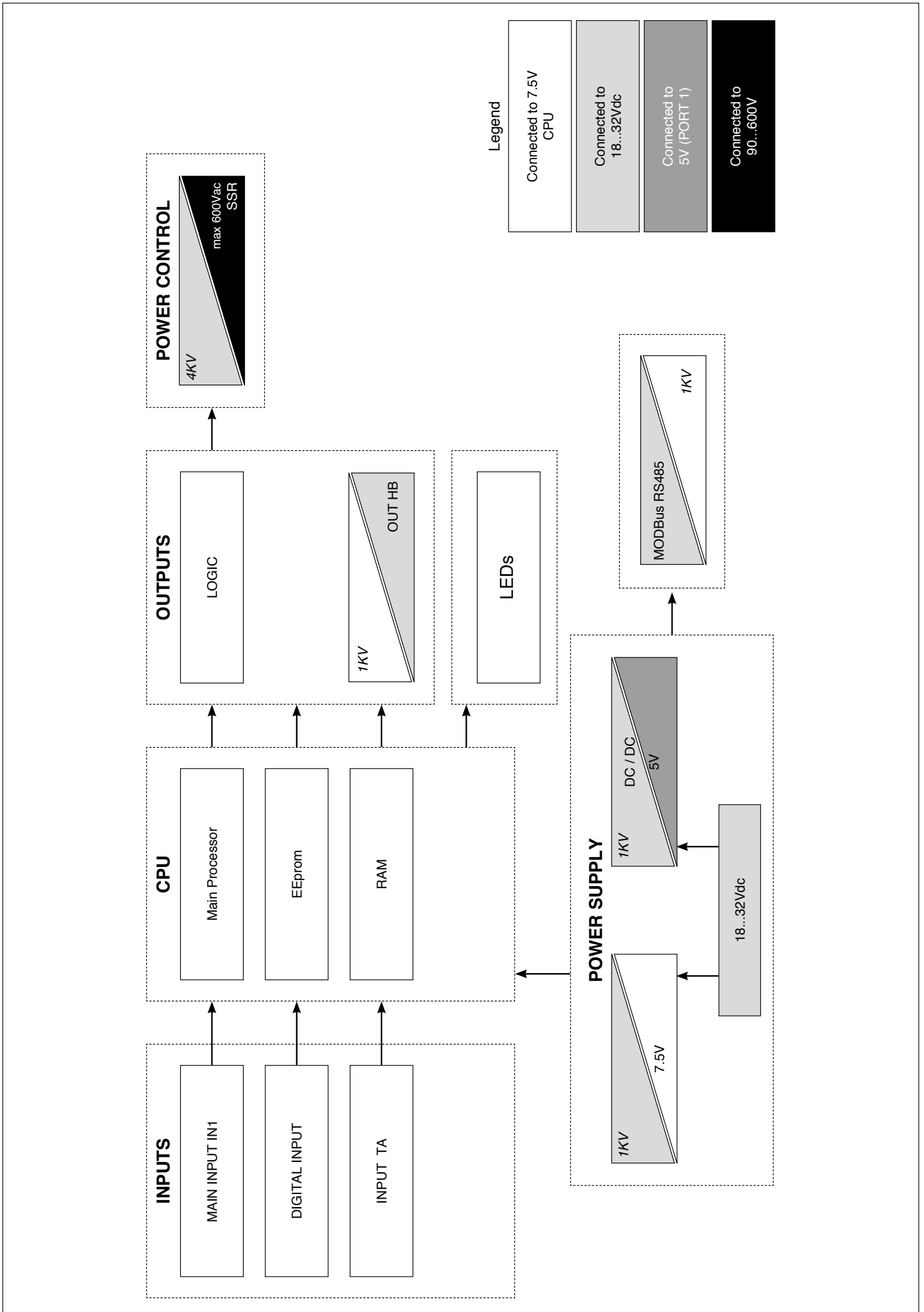

2.4 DIMENSIONS

Fastening may be done on DIN guide (EN50022) or with (5MA). See figures 1 and 2.
All dimensions are expressed in mm.

Figure 1

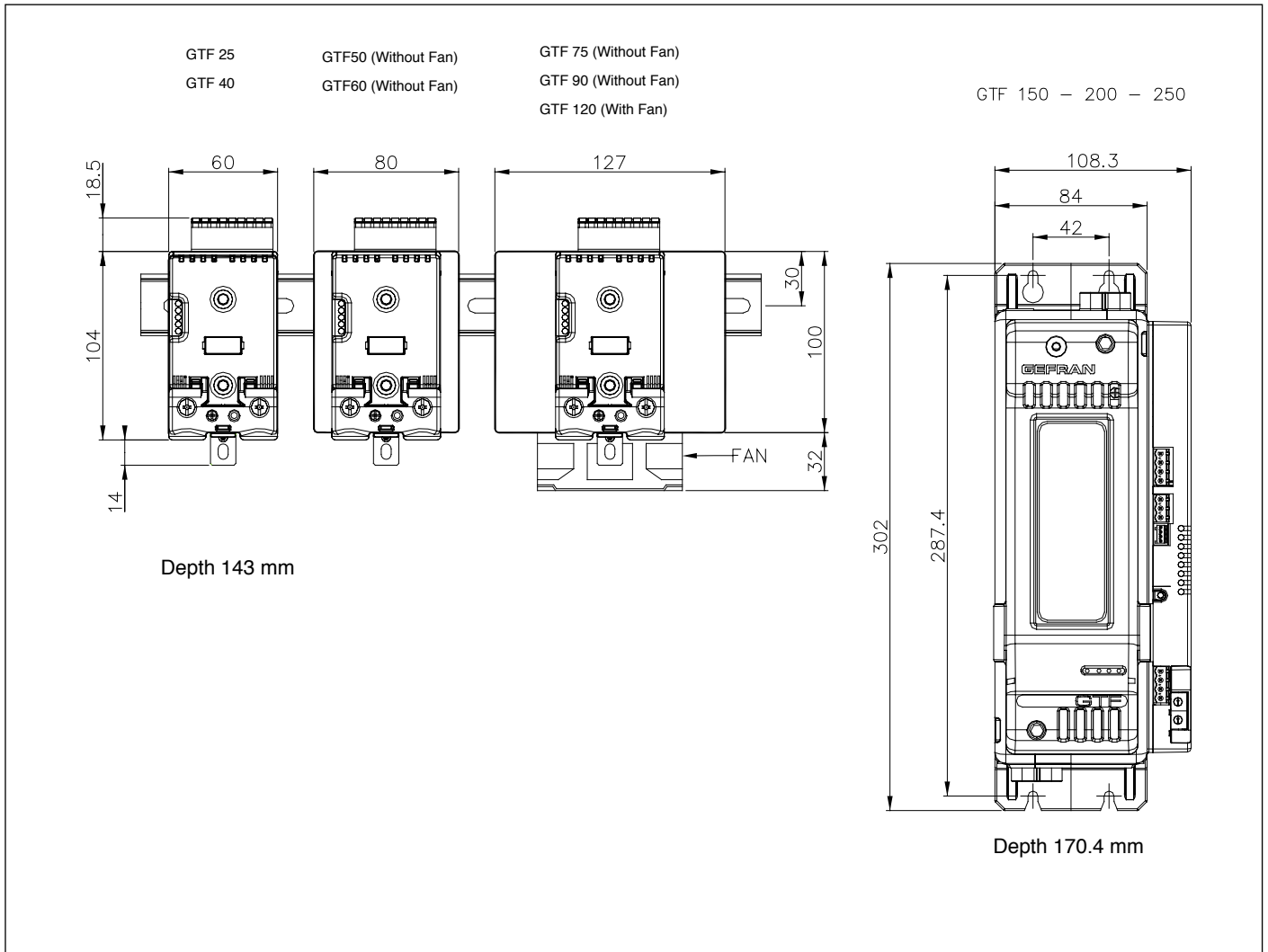

2.4.1 TEMPLATE DIMENSIONS

	L (mm)	W(mm)
Models		
GTF 25-40-50-60A:	112	44
GTF 75-90-120A:	112	113
GTF 150-200-250A	287	42

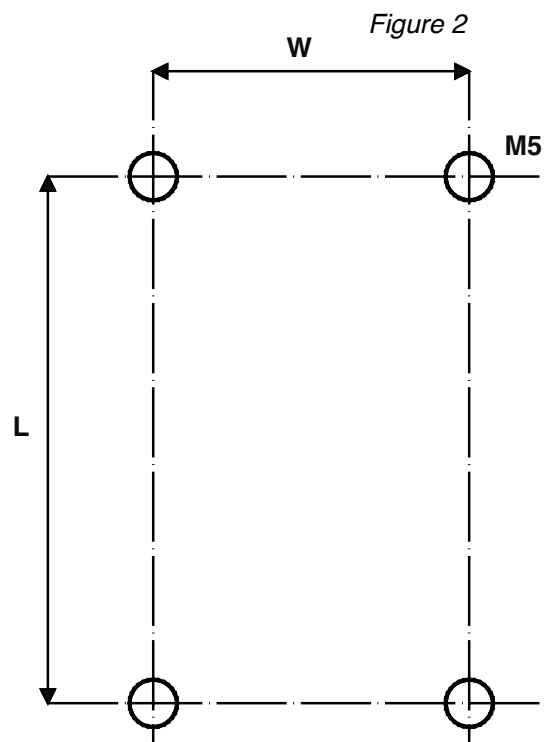



Attention: respect the minimum distances shown in figure 3 to provide adequate air circulation.

Figure 3

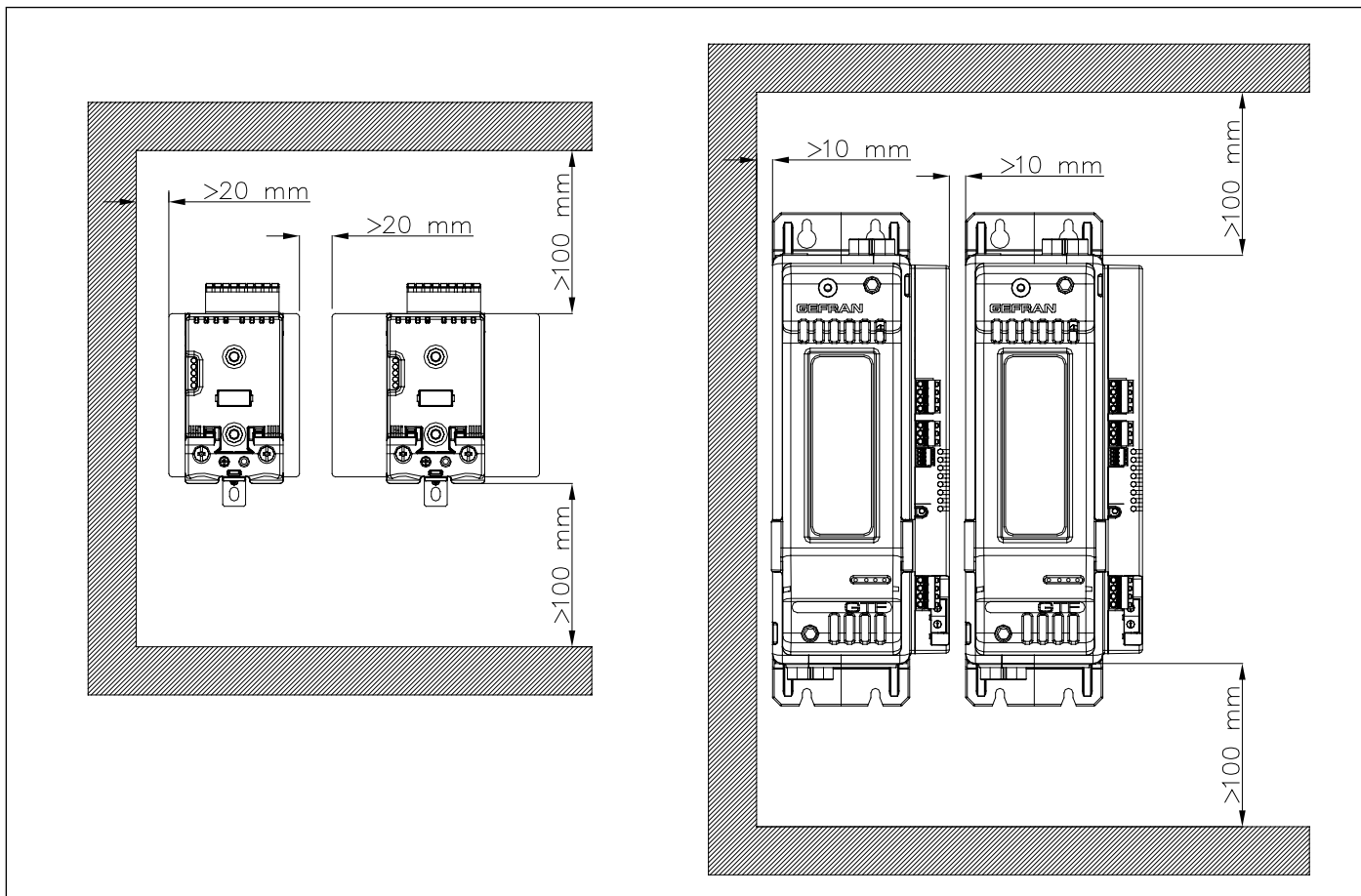

For correct attachment/release of the module on the DIN guide, do as follows:

- keep the attach/release cursor pressed
- insert/remove the module
- release the cursor

Figure 4

PHASE ATTACHMENT

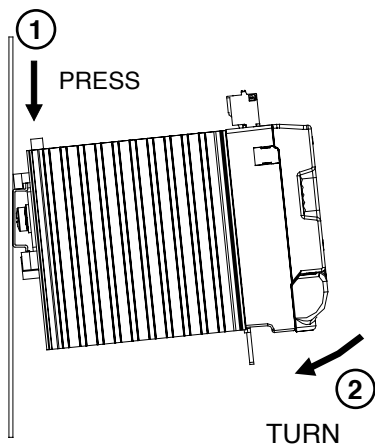

Figure 5

GTF
locked properly
to DIN bar

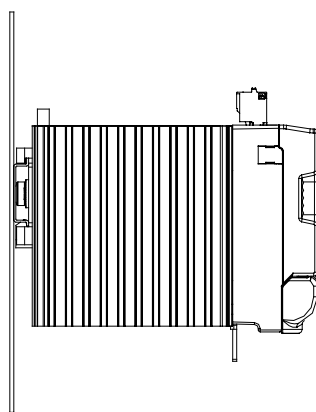

Figure 6

PHASE RELEASE

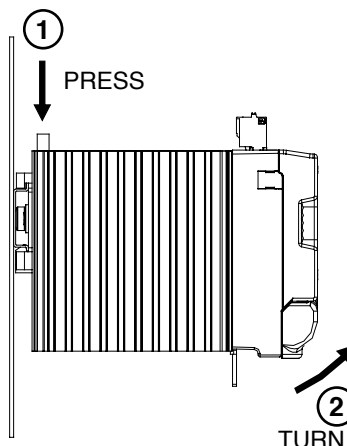

Figure 7

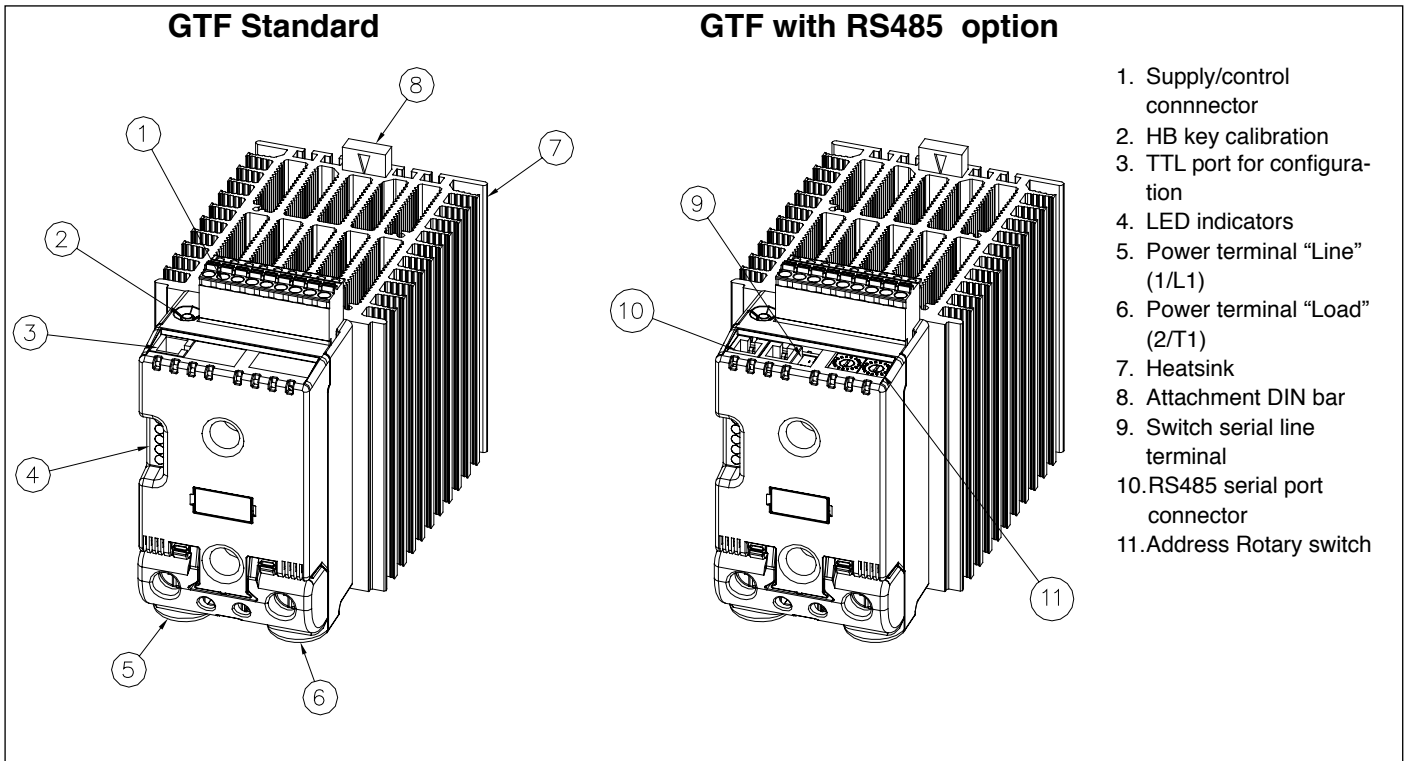

Figure 8

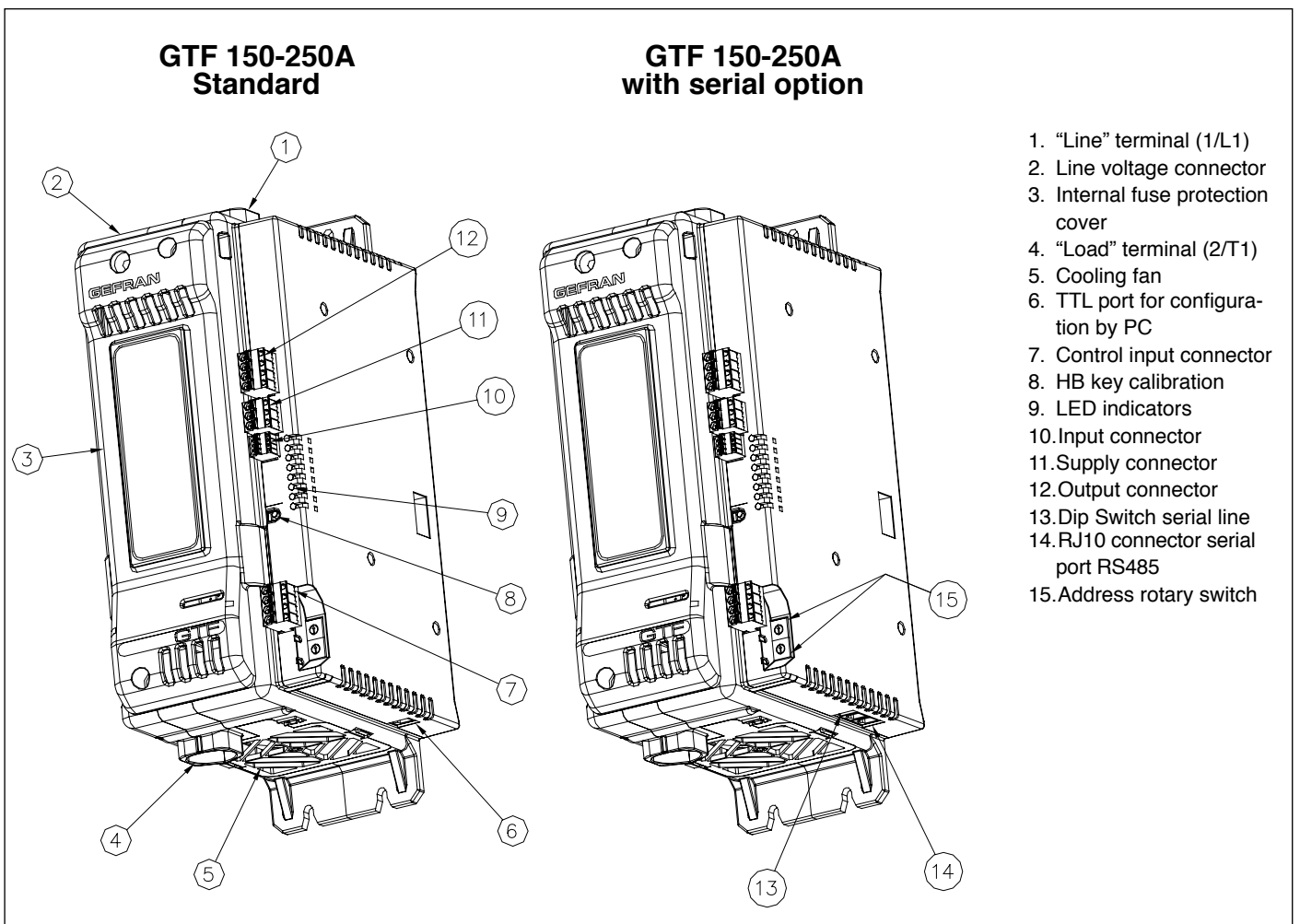
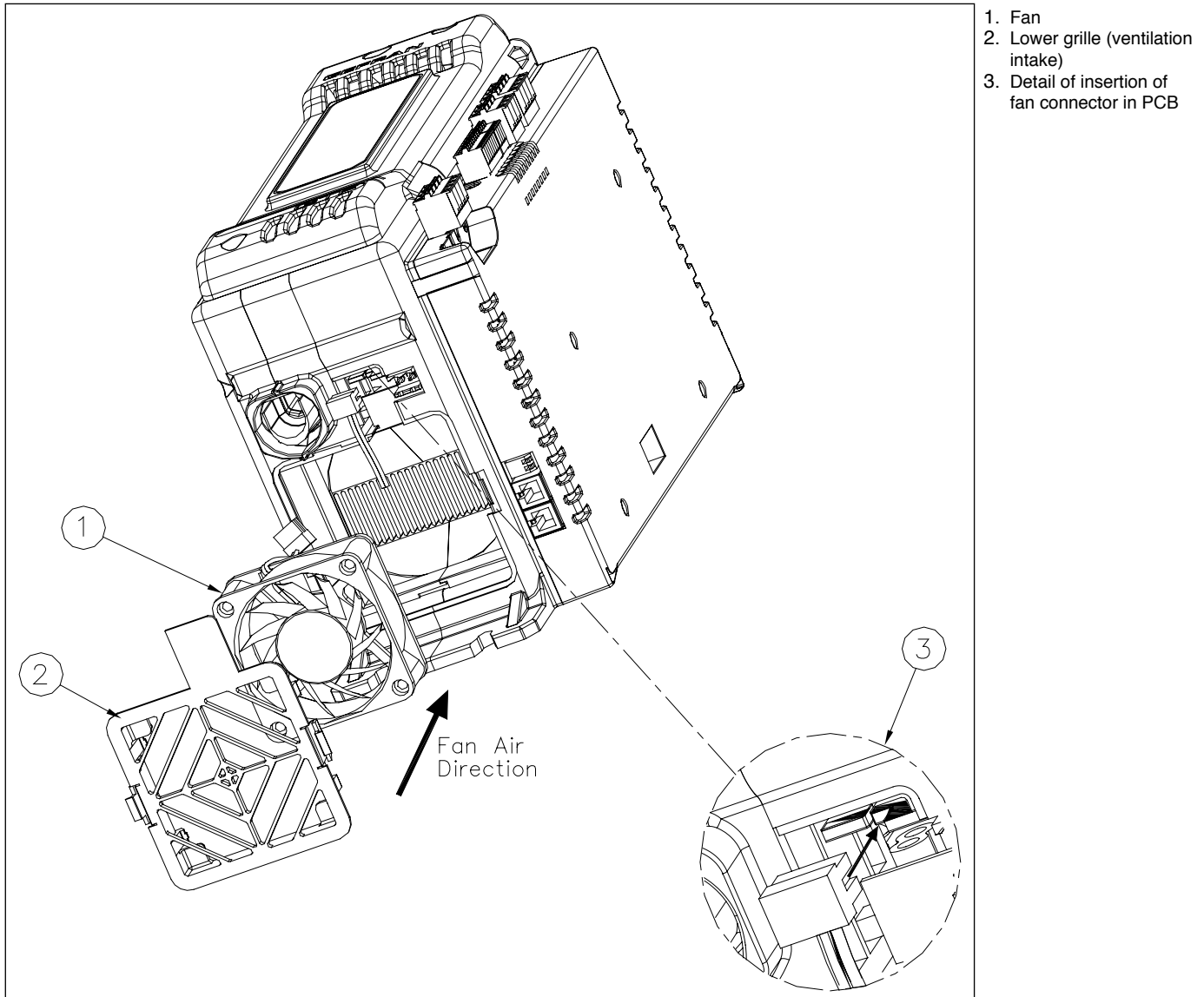

Figure 9



⚠ PERIODIC CLEANING

Every 6-12 months (depending on the dust level of the installation) blow a compressed air jet downward through the upper rectangular cooling grilles (on the side opposite the fan). This will clean the internal heat dissipater and the cooling fan.

⚠ IN CASE OF OVERHEAT ALARM

ATTENTION:

Before and during the inspection/maintenance cut power to the fan controller and verify that the system is isolated for operator safety.

If periodic cleaning does not eliminate the problem, do as follows:

- a Remove the fan support grille by detaching the two support tabs
- b Disconnect the fan connector from the board
- c Check the condition of the fan
- d Clean or replace the fan
Attention: check that the arrow (on the fan indicating the direction of air flow) is pointing to the heat sink
- e Insert the connector into the board
- f Insert the fan support grille until it attaches
- g Power up the device and check fan rotation when at least one load is on

2.9 REPLACING THE INTERNAL FUSE (OPTIONAL ONLY FOR GTF 150-250A)

⚠ ATTENTION:

Before and during the inspection/maintenance cut power to the fuse controller and verify that the system is isolated for operator safety.

- Undo the cover fastening screw (1)
- Remove the cover following the movement indicated by the arrow (2)
- In this way the fuse is discovered (3)
- Loosen the two fastening nuts of fuse by means of fixed spanner N.13 (GTF 150)
- It is not necessary to remove the nuts as the fuse N.17 (GTF 200-250A) is slipped off its seat by turning it (4) and extracting it (5) as indicated by the arrows
- Insert the new fuse as indicated by the arrows (6,7)

WARNING: the washer must remain between the dice and the fuse (NOT under the fuse).

Figure 10

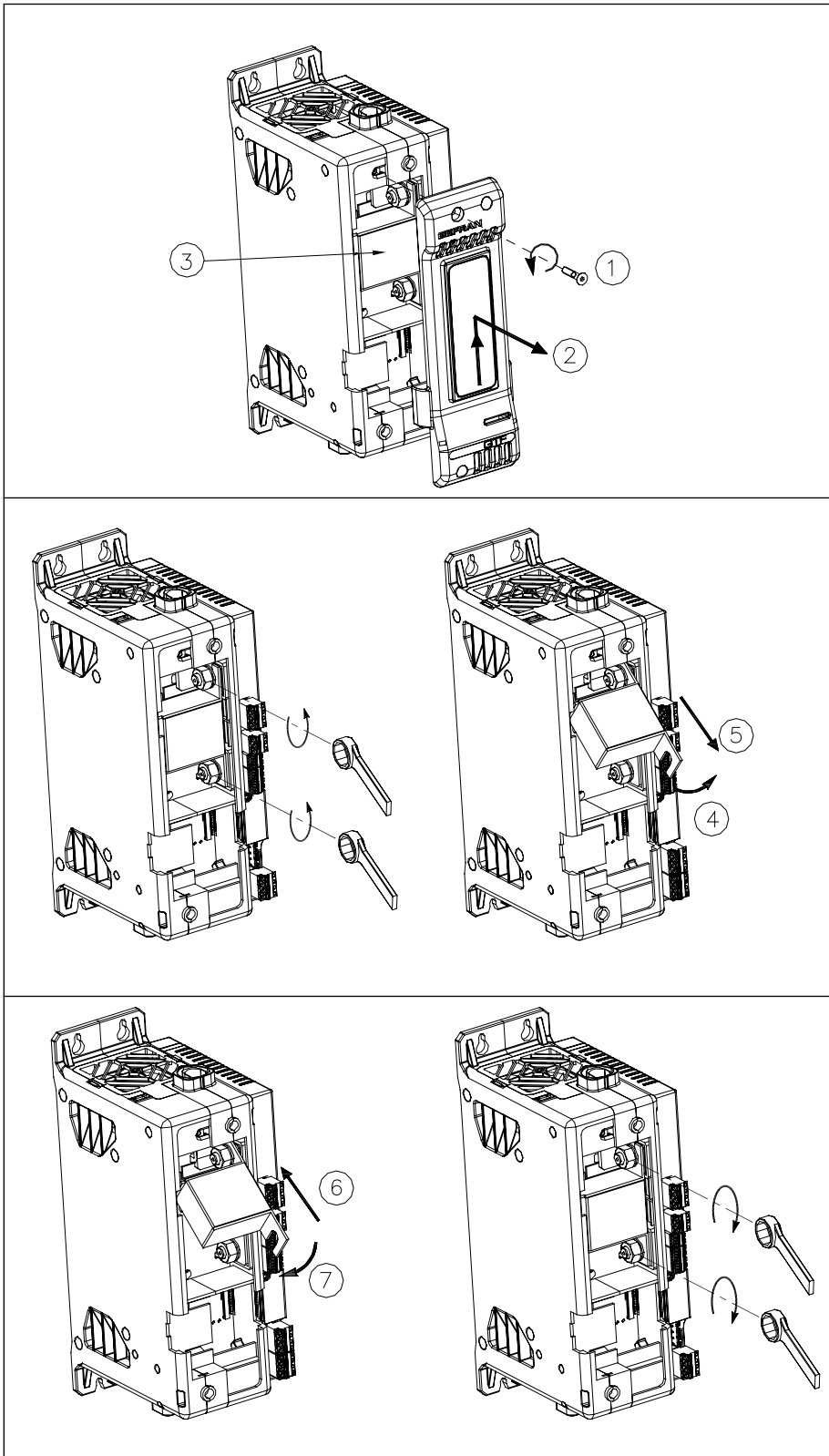

- Fasten the two nuts by the 3-4 Nm torque tube-shaped spanner N. 16
- Replace the cover pointing it to the lower part (pay attention to the connection tooth)
- Fasten the cover by the specific screw

3.1 POWER CONNECTIONS

RECOMMENDED WIRE GAUGES

Table 4

GTF CURRENT LEVEL	TERMINAL	CABLE WIRE	WIRE TERMINAL	TIGHTENING TORQUE / TOOL
25A	1/L1, 2/T1, PE	4 mm ² 10 AWG	Wire terminal / Eye D. 6mm	2 ...2.5 Nm / Phillips screwdriver PH2 - PH3
40A	1/L1, 2/T1, PE	10 mm ² 7 AWG	Wire terminal / Eye D. 6mm	2 ...2.5 Nm / Phillips screwdriver PH2 - PH3
50A	1/L1, 2/T1, PE	10 mm ² 7 AWG	Wire terminal / Eye D. 6mm	2 ...2.5 Nm / Phillips screwdriver PH2 - PH3
60A	1/L1, 2/T1, PE	16 mm ² 5 AWG	Wire terminal / Eye D. 6mm	2 ...2.5 Nm / Phillips screwdriver PH2 - PH3
75A	1/L1, 2/T1, PE	25 mm ² 3 AWG	Wire terminal / Eye D. 6mm	2 ...2.5 Nm / Phillips screwdriver PH2 - PH3
90A	1/L1, 2/T1, PE	35 mm ² 2 AWG	Wire terminal / Eye D. 6mm	2 ...2.5 Nm / Phillips screwdriver PH2 - PH3
120A	1/L1, 2/T1, PE	50 mm ² 1/0 AWG	Wire terminal / Eye D. 6mm	2 ...2.5 Nm / Phillips screwdriver PH2 - PH3
-	3/L2 (Ref. Vline)	0.25 ...2.5 mm ² 23...14 AWG	wire terminal tip	0.5 ...0.6 Nm / Screwdriver blade 0.6 x 3.5 mm
150A	1/L1, 2/T1	70 mm ² 2/0 AWG	Wire stripped for 25 mm or with crimped pre-insulated terminal tube CEMBRE PKC70022	5 ... 6 Nm / No. 6 hex head wrench
200A	1/L1, 2/T1	95 mm ² 4/0 AWG	Wire stripped for 25 mm or with crimped pre-insulated terminal tube CEMBRE PKC95025	5 ... 6 Nm / No. 6 hex head wrench
250A	1/L1, 2/T1	120 mm ² 250 AWG	Wire stripped for 25 mm	5 ... 6 Nm / No. 6 hex head wrench
-	3/L2 (Ref. Vline)	0.25 ...2.5 mm ² 23...14 AWG	Wire stripped for 8 mm or with tag terminal	0.5 ...0.6 Nm / Flat-head screwdriver tip 0,6 x 3.5 mm

3.2 CONNECTIONS INPUT/OUTPUT GTF 25-120A

Figure 11

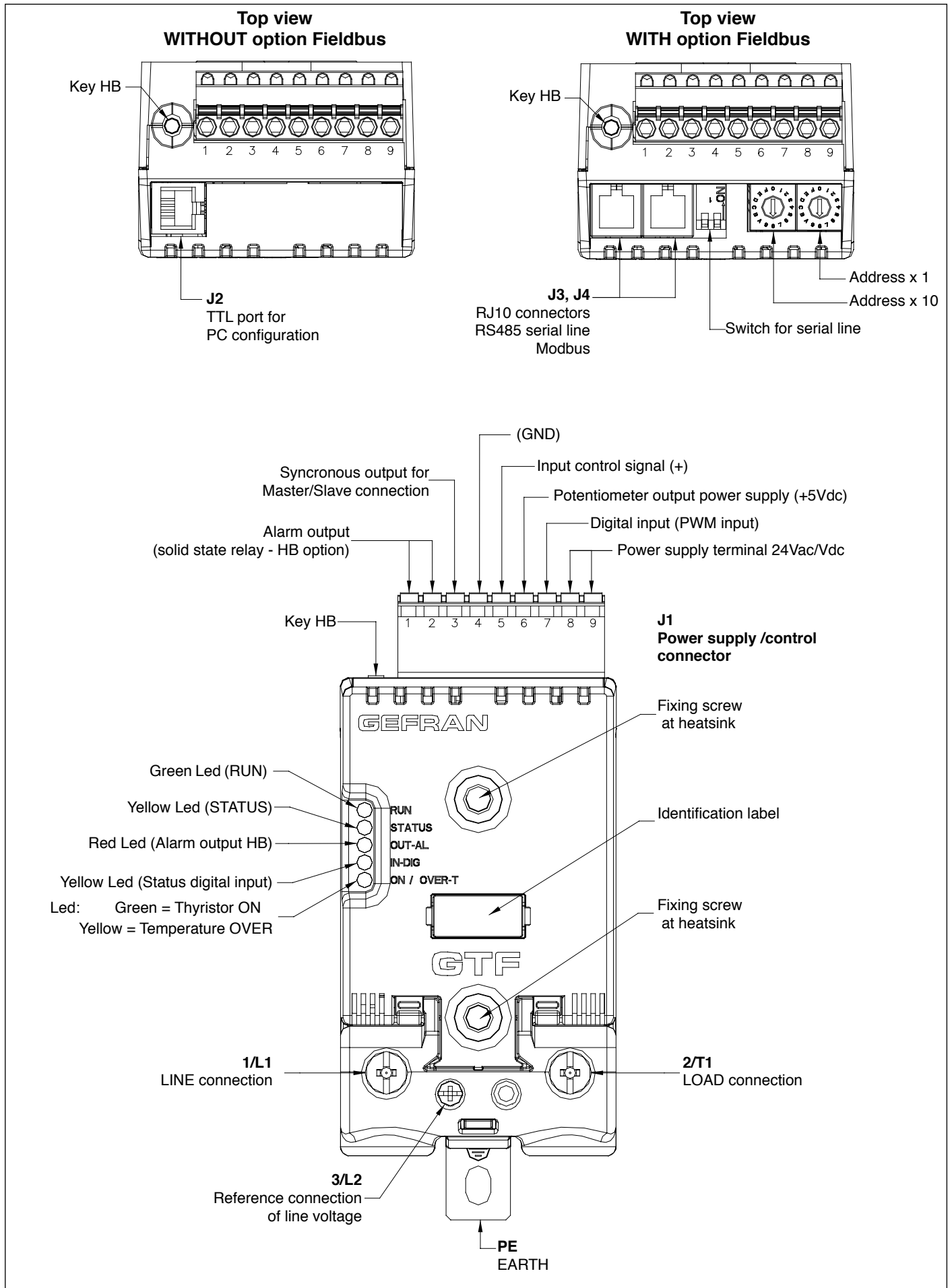
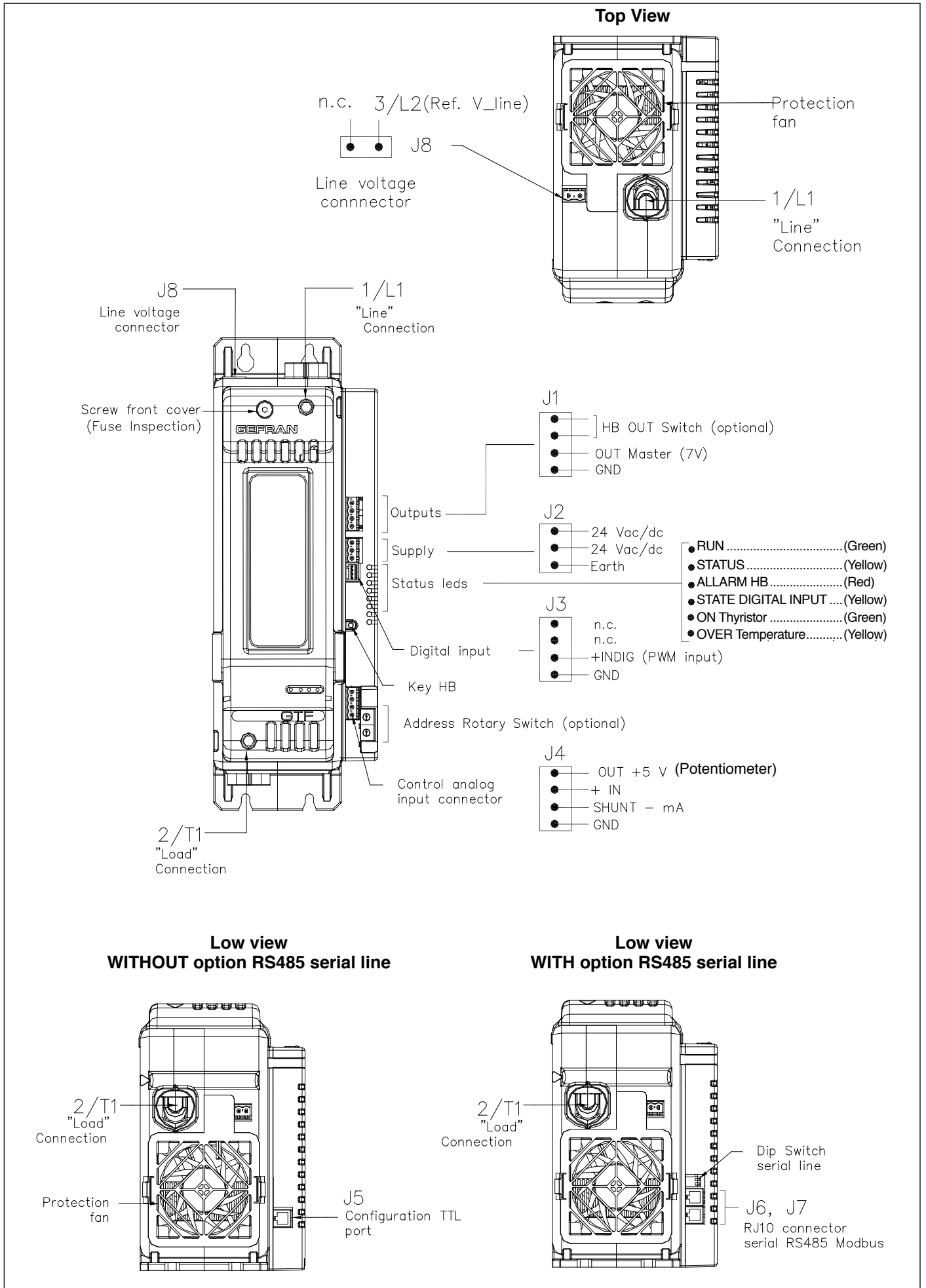

Figure 12



3.4 FUNCTIONS OF INDICATOR LEDs

Description of LEDs

Table 5

LED	DESCRIPTION	COLOR
RUN	Flashing during normal operation	green
	On steadily: according to FW setting (see SW manual)	
STATUS	Off : during normal operation	yellow
	On : according to FW setting (see SW manual)	
ALARM	State HB alarm output / Power Fault Alarm / Fuse Open	red
DI	State digital input	yellow
ON / OVER-TEMP	.Green: thyristor on control state	green
	Yellow: ON Thyristor overtemperature alarm	yellow



The state of the LEDs matches the corresponding parameter, except in the following special cases:

- LED 1 (green) + LED 2 (yellow) both flashing rapidly: autobaud in progress
- LED 2 (yellow) flashing rapidly: SSR temperature sensor broken or SSR Over Heat or Rotation Error or Fuse_open (GTF 150...250A)
- or Short_Circuit_Current or Line-Load Terminals Over Heat (GTF 150...250A)

3.5 CONTROL CONNECTOR

3.5.1 CONNECTOR J1 GTF 25-120A

Figure 13

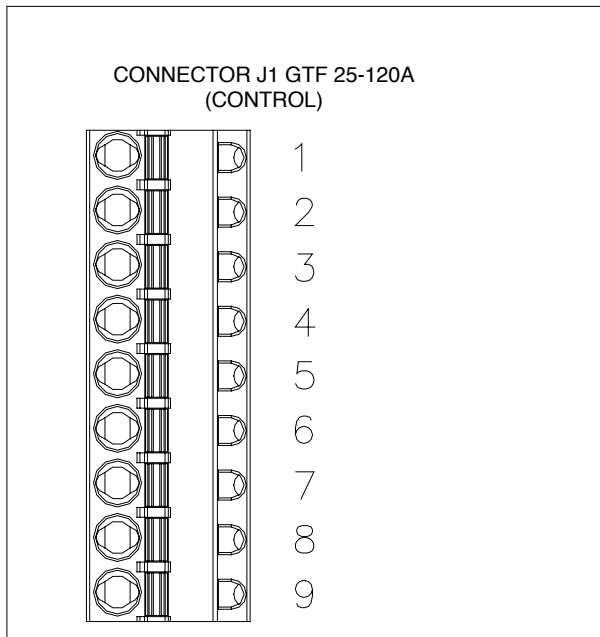

Table 6

	0,2 - 2,5mm ²	24-14AWG
	0,25 - 2,5mm ²	23-14AWG

Figure 14 Connection schema J1 GTF for 25-120A

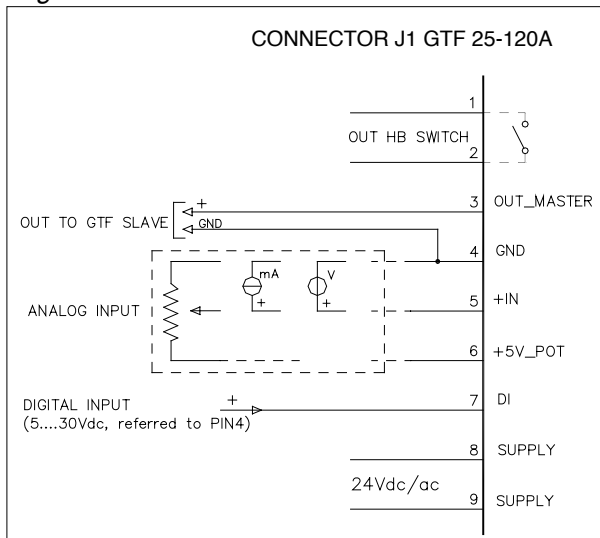

Table 7

PIN	NAME	DESCRIPTION
1	OUT AL HB	OUT Alarm Switch (HB)
2		
3	OUT_Master	Control output Slave (+7V)
4	GND	GND Control analog input
5	+ IN	+ Control analog input
6	+5V_POT	Output alim. potentiometer
7	IN_DIG	Digital input & PWM Input
8	24V Supply	Supply 18...32 Vac/Vdc
9	24V Supply	

3.5.2 CONNECTOR J1 GTF 150-250A OUTPUT

Figure 15

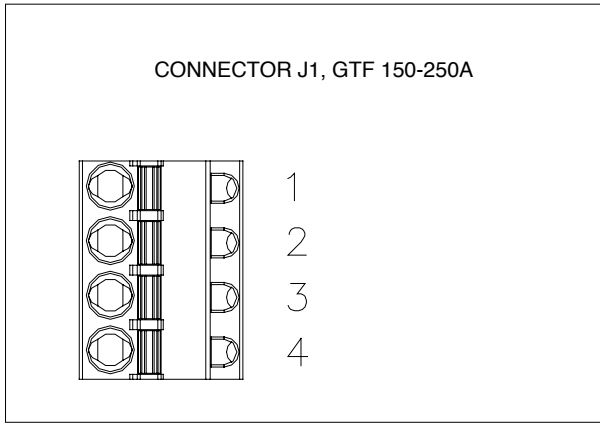

Table 8





	0,2 - 2,5mm ²	24-14AWG
		
	0,25 - 2,5mm ²	23-14AWG
		

Figure 16 Connection scheme J1 GTF for 150-250A

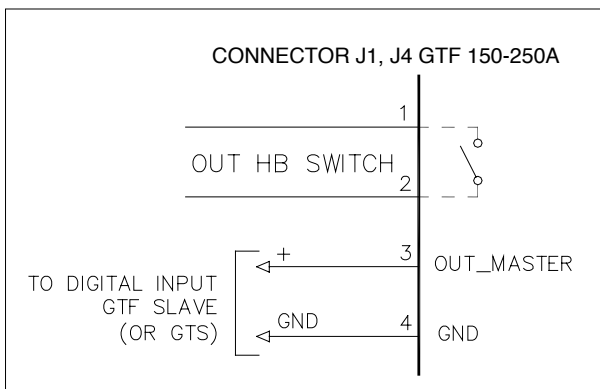

Table 9

PIN	NAME	DESCRIPTION
1	OUT AL HB	Contact output N.A. Alarm HB
2		
3	+OUT_Master	Output 7Vdc for control slave module
4	GND	GND output OUT_Master

3.5.3 CONNECTOR J2 GTF 150-250A SUPPLY 24V

Figure 17

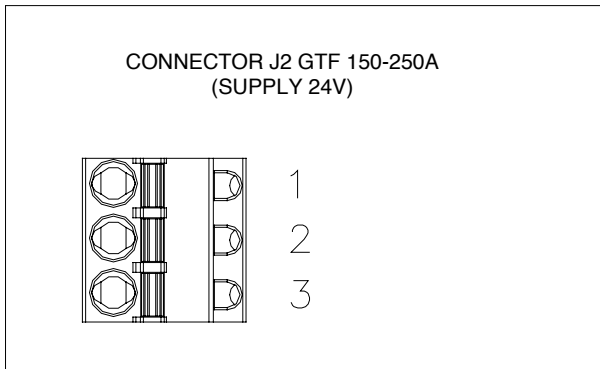

Table 10

	0,2 - 2,5mm ²	24-14AWG
		
	0,25 - 2,5mm ²	23-14AWG
		

Figure 18 Connection scheme J2 for GTF 150-250A

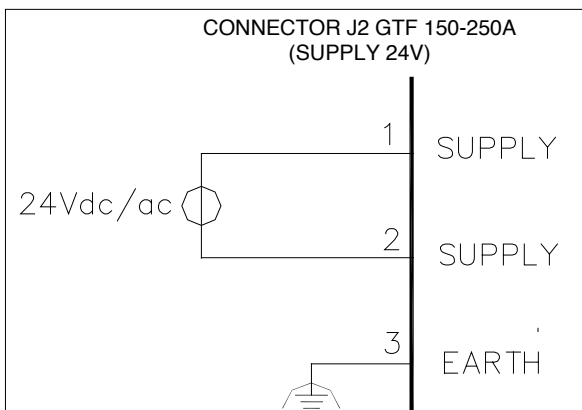

Table 11

PIN	NAME	DESCRIPTION
1	24Vdc/Vac	24V Supply
2	24Vac/Vdc	
3	EARTH	Earth EMC

3.5.4 CONNECTOR J3 GTF 150-250A DIGITAL INPUT

Figure 19

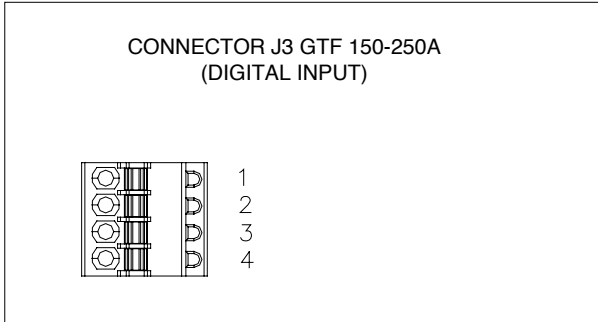

Table 12





	0,14 - 0,5mm ²	28-20AWG
		
	0,25 - 0,5mm ²	23-20AWG
		

Figure 20 Connection scheme J3 for GTF 150-250A

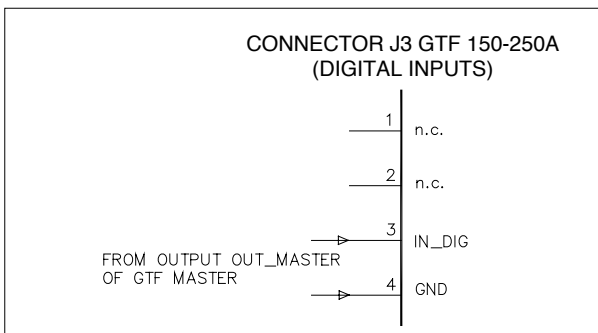

Table 13

PIN	NOME	DECRPTION
1	---	Not connected
2	---	Not connected
3	+IN_DIG	Digital input (& PWM input)
4	GND	24V Supply

3.5.4 CONNECTOR J4 GTF 150-250A CONTROL ANALOG INPUT

Figure 21

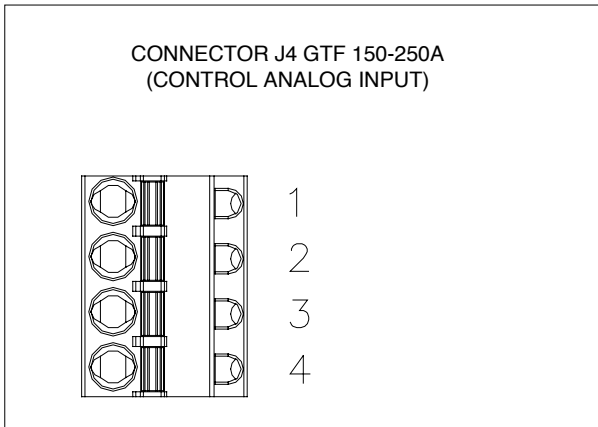

Table 14

	0,2 - 2,5mm ²	24-14AWG
		
	0,25 - 2,5mm ²	23-14AWG
		

Figure 22 Connection scheme J4 for GTF 150-250A

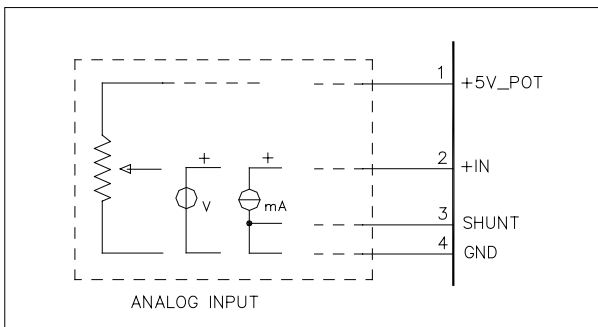
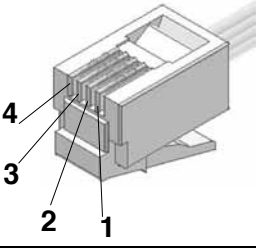

Table 15

PIN	NAME	DECRPTION
1	OUT AL HB	Supply output 5V potentiometer
2	+IN	Control voltage input
3	SHUNT	Shunt for input mA
4	GND	GND control signal

3.6 CONFIGURATION TTL PORT (GTF STANDARD)

CONNECTOR J2 GTF 25-120A - CONNECTOR J5 GTF 150-250A

Connector S1/S2 RJ10 4-4 pin	Nr. Pin	Nome	Description	Note
	1	GND	Ground	The use of this port is recommended to configure parameters by Accessory Gefran cable code F049095 (USB / TTL) or Gefran cable code F043956 (RS232 / TTL) ONLY
	2	RX_TTL	Data reception TTL from GTF	
	3	TX_TTL	Data transmission TTL to GTF	
	4	(Reserved Gefran)	DO NOT connect	
Cable type: flat telephone cable for pin 4-4 conductor 28AWG				

3.7 SERIAL COMMUNICATION PORTS MODBUS RS485 (Option)

CONNECTORS J3, J4 GTF 25-120A - CONNECTORS J6, J7 GTF 150-250A

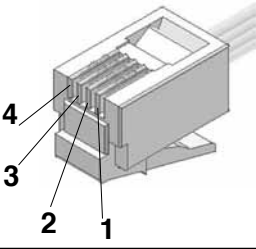
Connector S1/S2 RJ10 4-4 pin	Nr. Pin	Name	Description	Note
	1	GND1 (**)		(*) Insert the RS485 line termination in the last device on the Modbus line, see dip-switches. (**) Connect the GND signal between Modbus devices with a line distance > 100 m.
	2	Tx/Rx+	Data reception/transmission (A+)	
	3	Tx/Rx+	Data reception/transmission (B-)	
	4	+V (reserved)		
Cable type: flat telephone cable for pin 4-4 conductor 28AWG				

3.8 CONNECTION EXAMPLE: COMMUNICATION PORTS

Integration of GTF with GEFLEX modules connected in RS485 Modbus

Figure 23

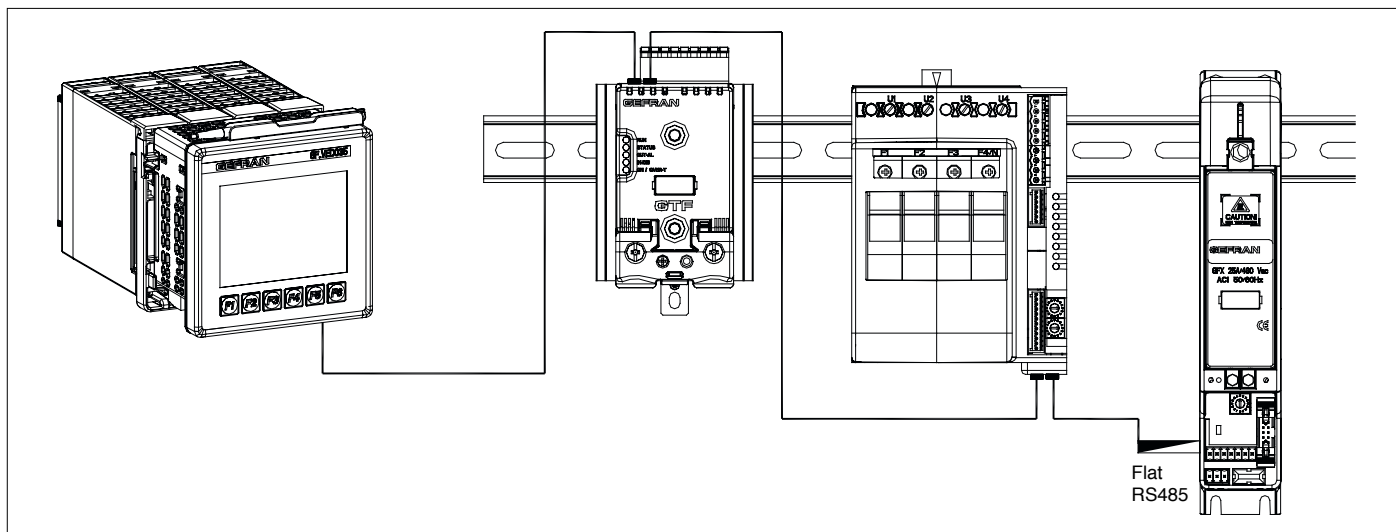

3.9 CONNECTION EXAMPLE: POWER SECTION

Connection example GTF 25-120A for 1 single-phase load, single-phase line (L1-N) or open delta (L1-L2)

Figure 24

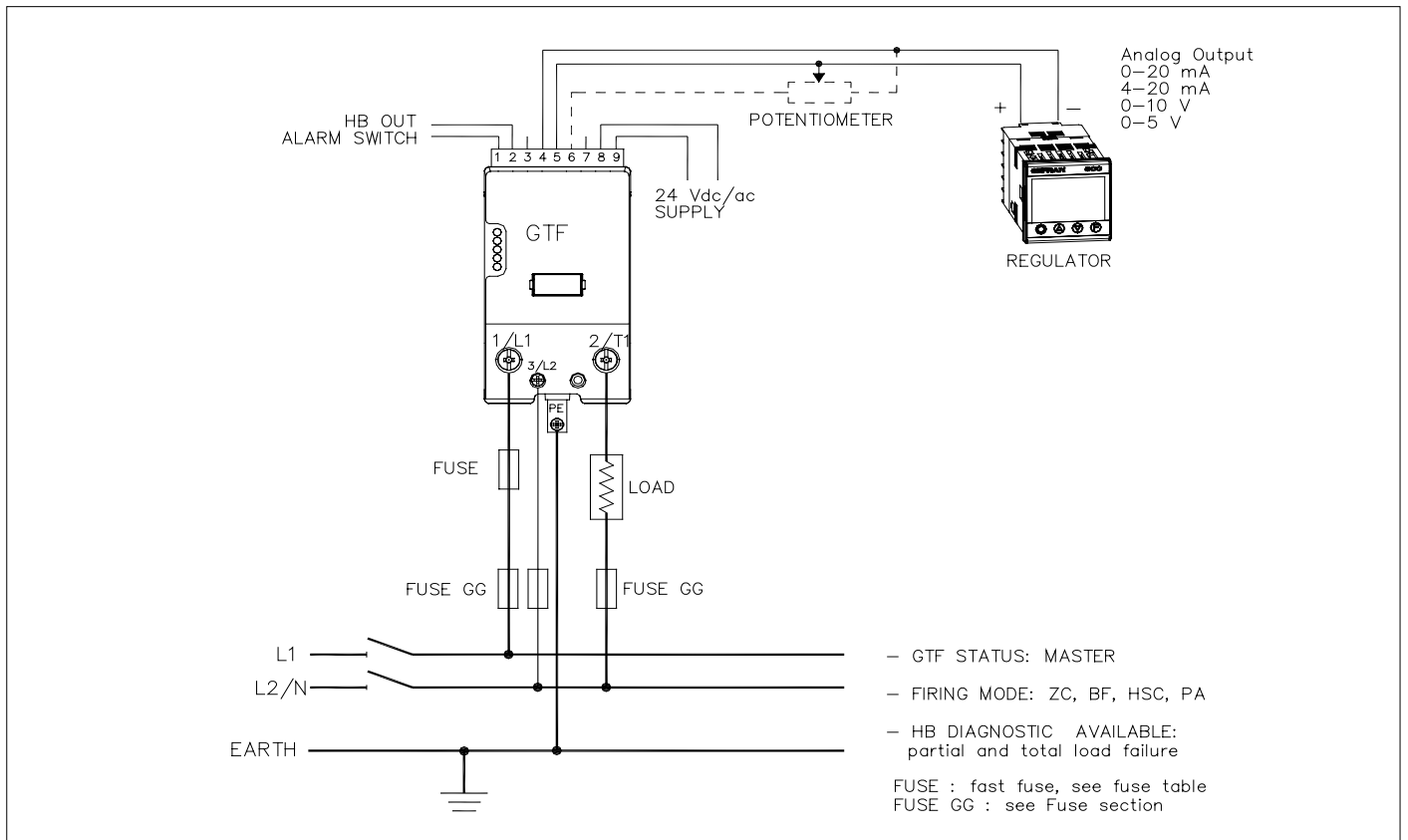

Connection example GTF 150A -250A 1 single-phase load, single-phase line L1-L2/N

Figure 25

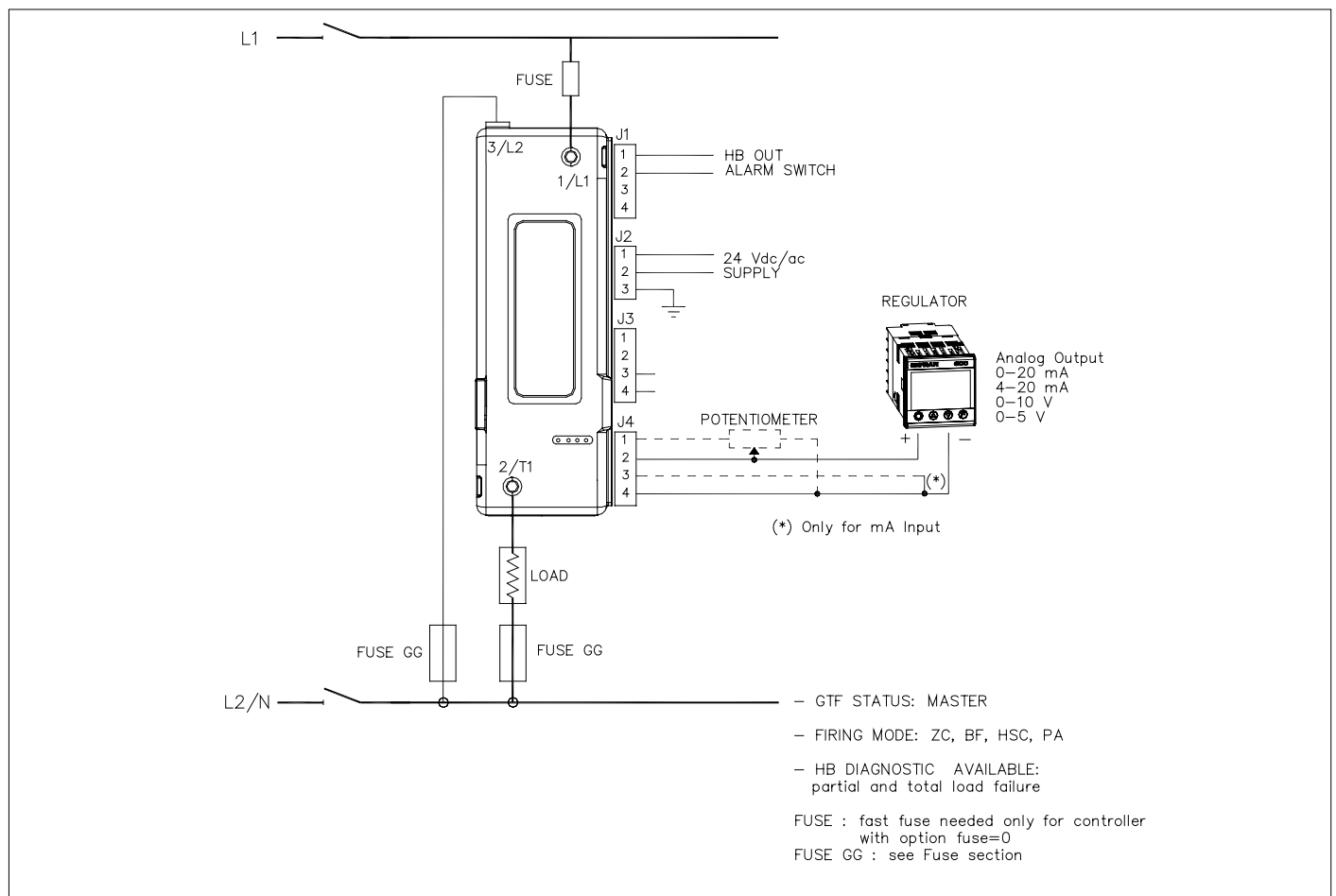

Connection example GTF 25-120A for 1 single-phase load with transformer single-phase line (L1-N) or open delta (L1-L2).

Figure 26

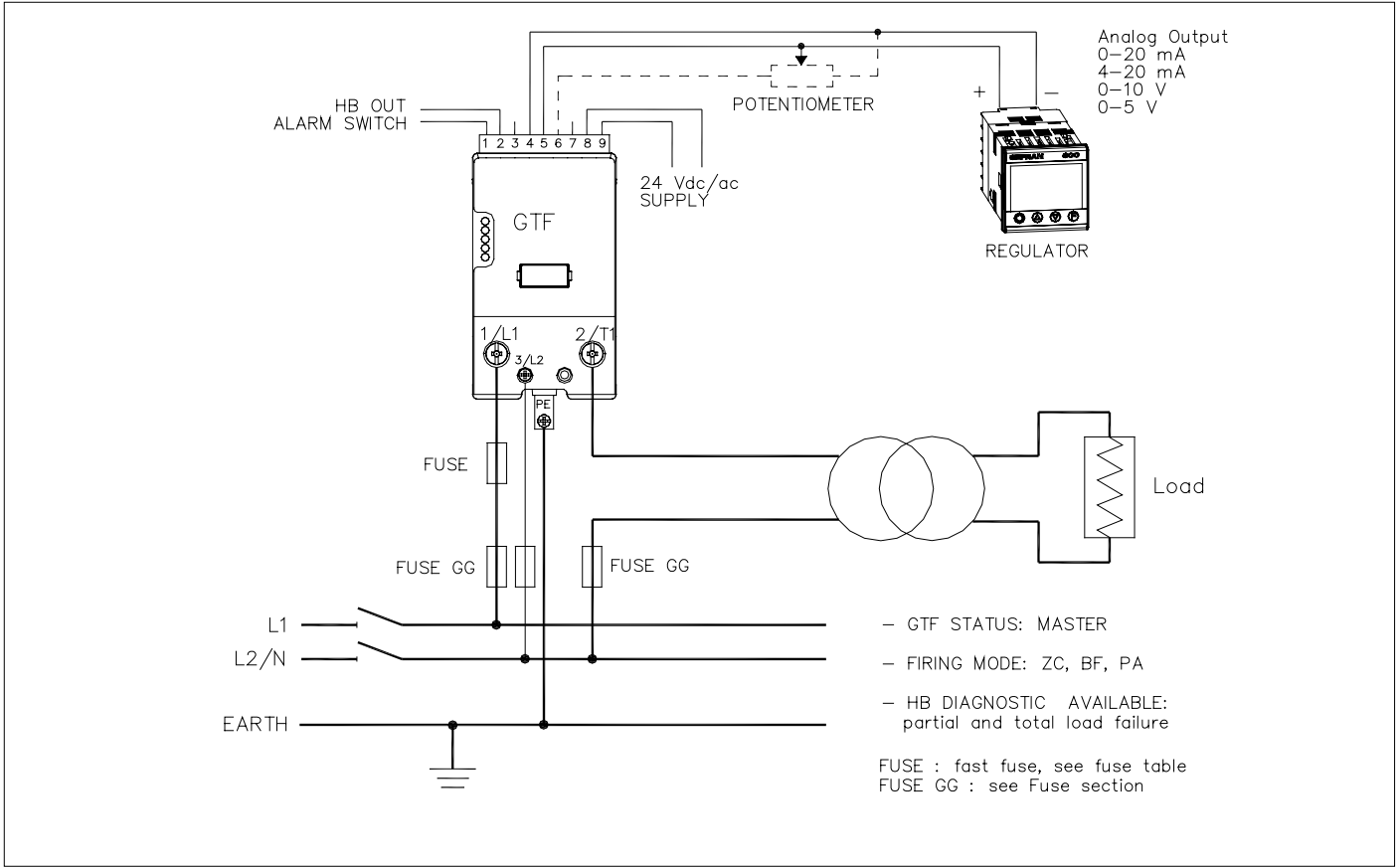

Connection example GTF 150A -250A for 1 single-phase load with transformer single-phase line L1-L2/N.

Figure 27

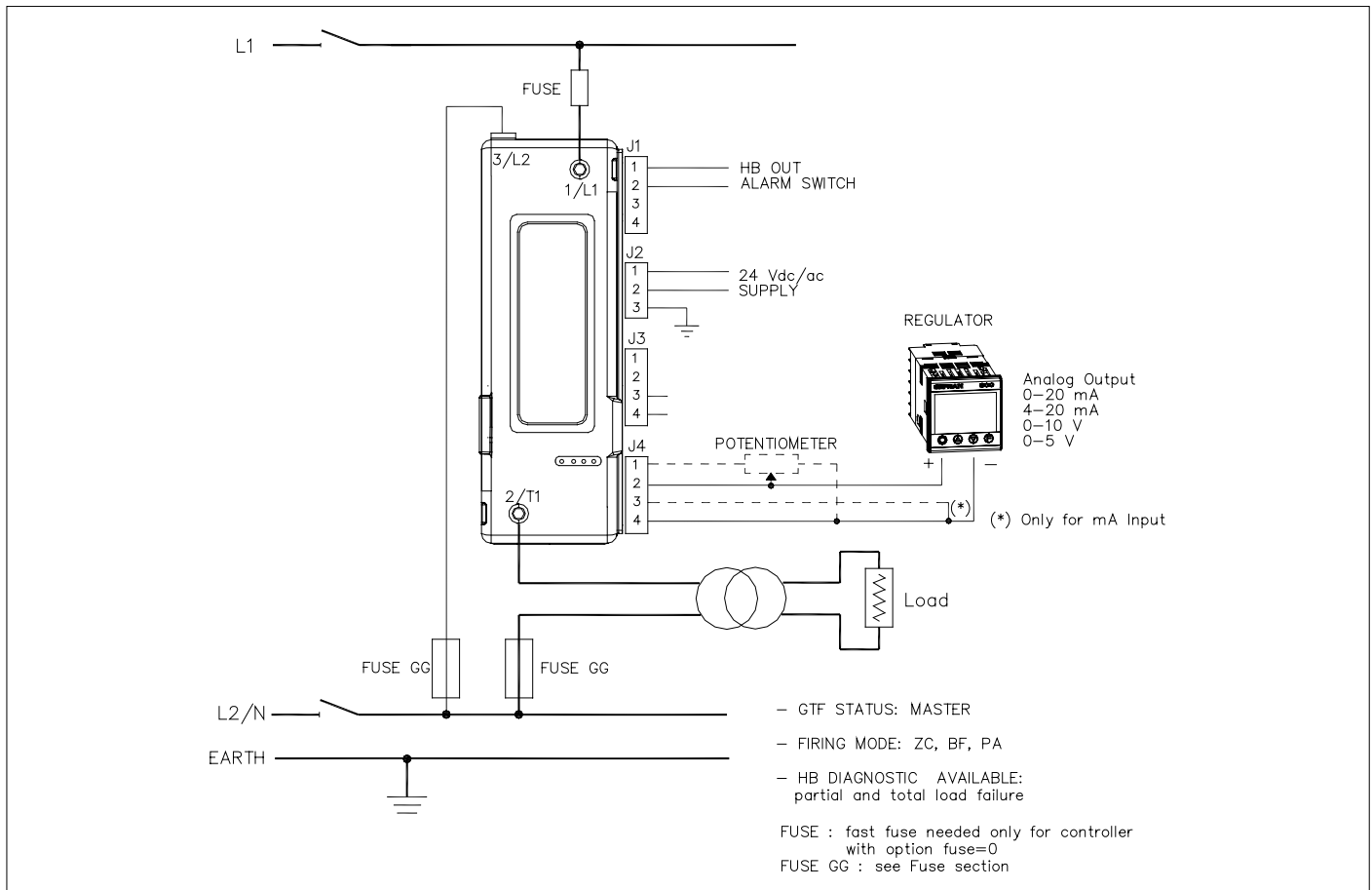

Connection example 2-phase (Master-Slave) GTF 25-120A for one load 3-phase

Figure 28

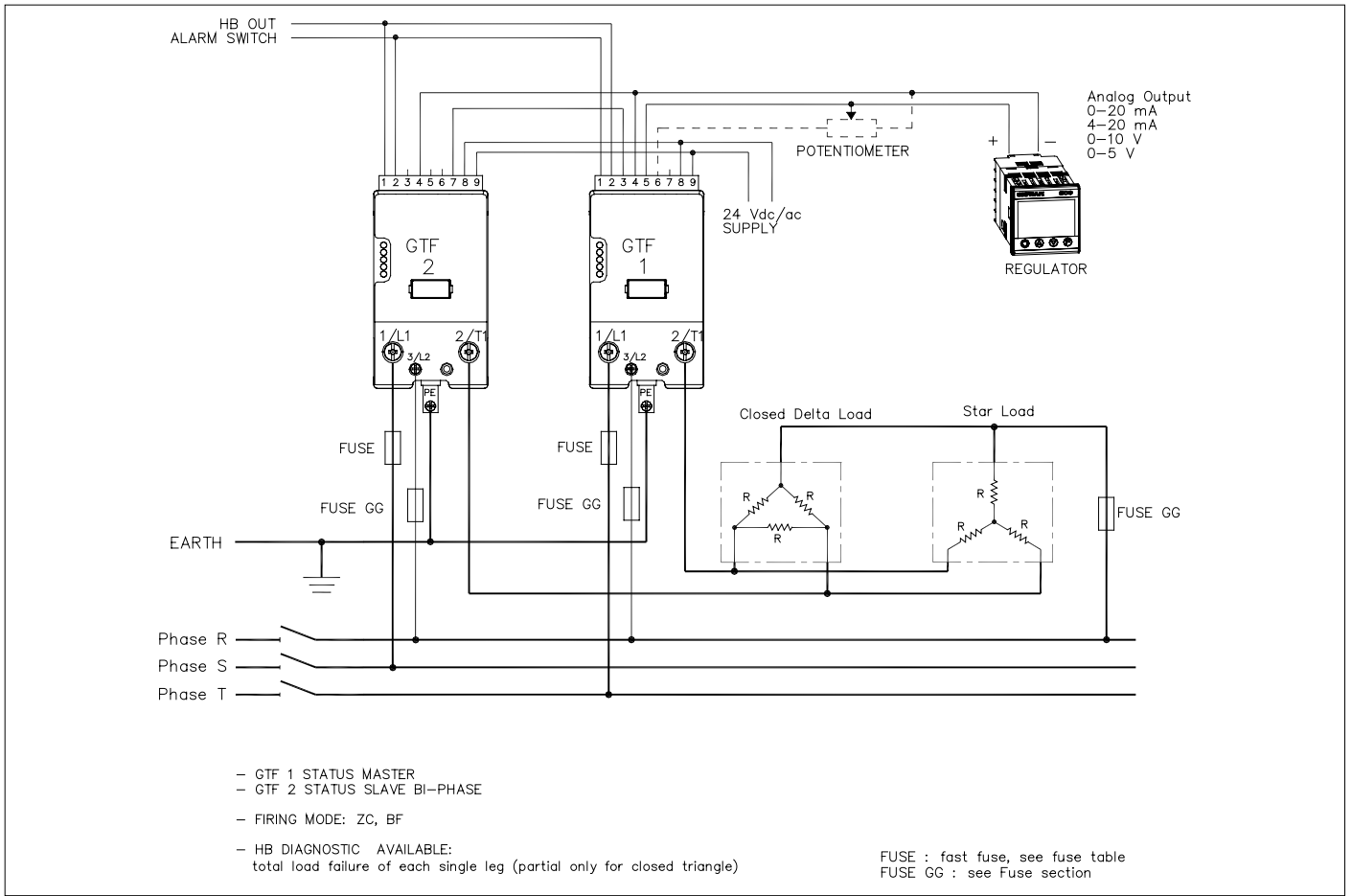

Connection example 2-phase (Master-Slave) GTF 150-250A for one load 3-phase

Figure 29

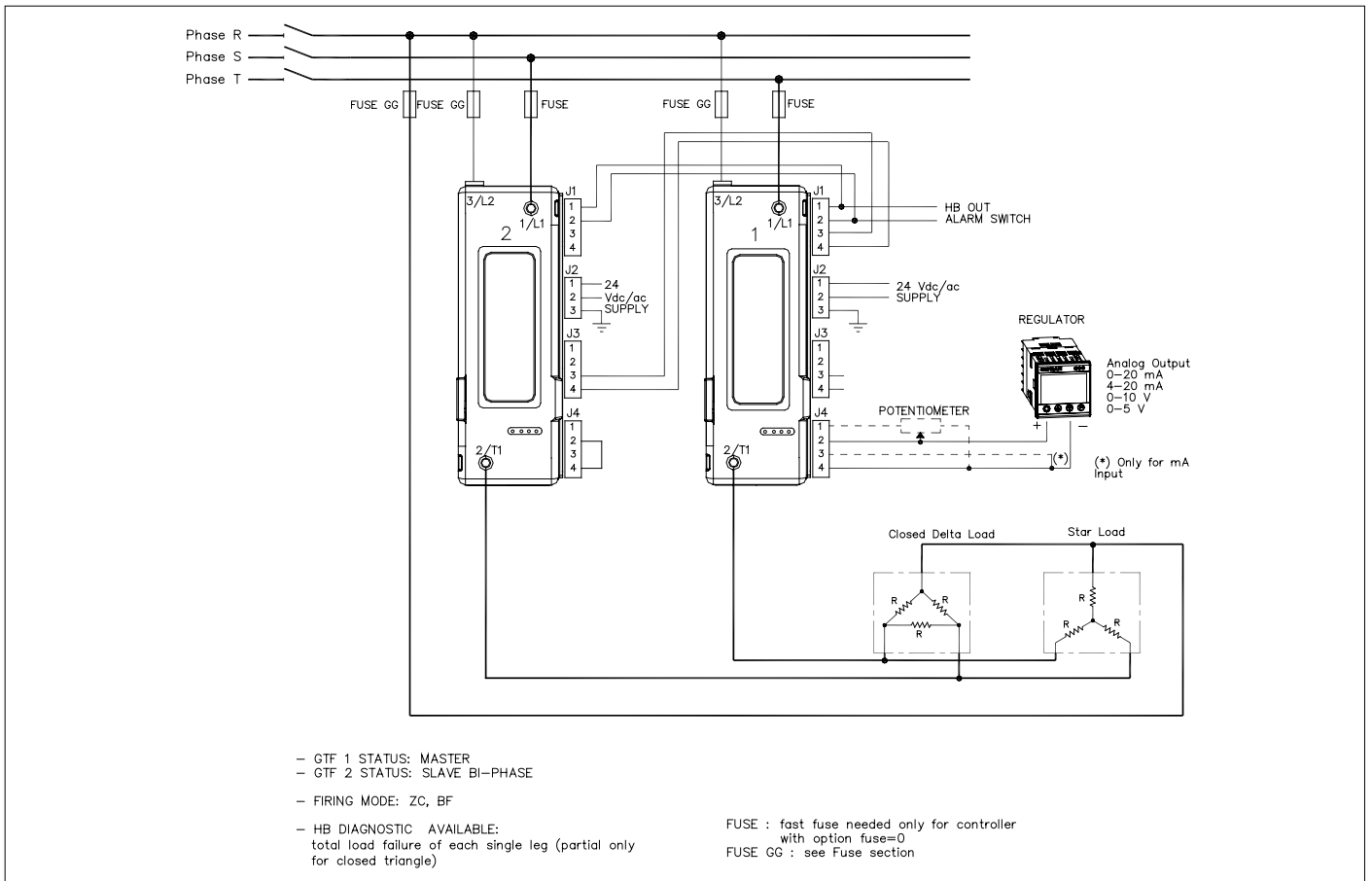

Connection example 3-phase GTF 150A-250A (Master-Slave control on 3 lines) for one load 3-phase

Figure 31

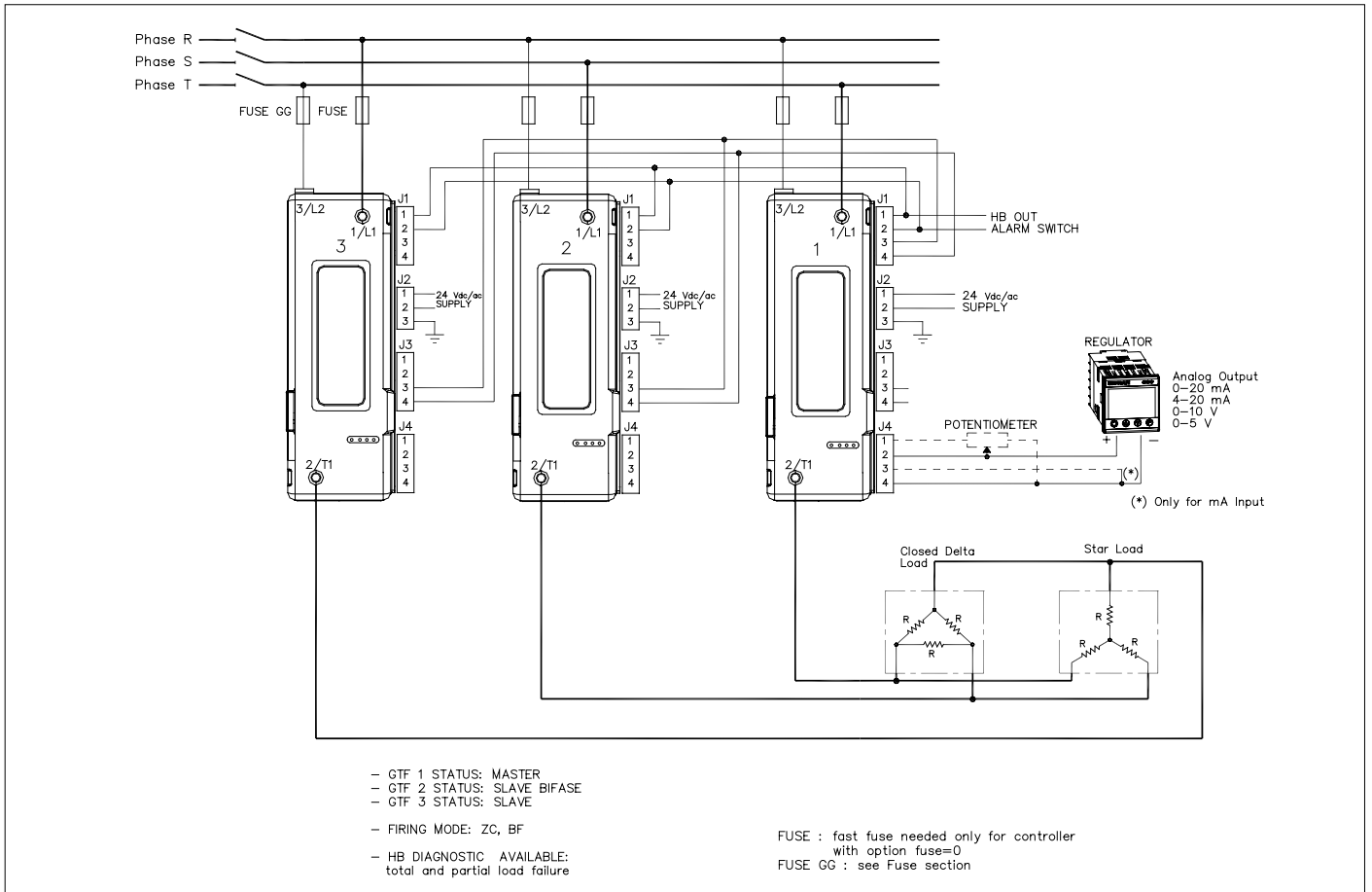

Connection example 2-phase GTF 25-120A (Master) with GTS (slave) for one load 3-phase

Figure 32

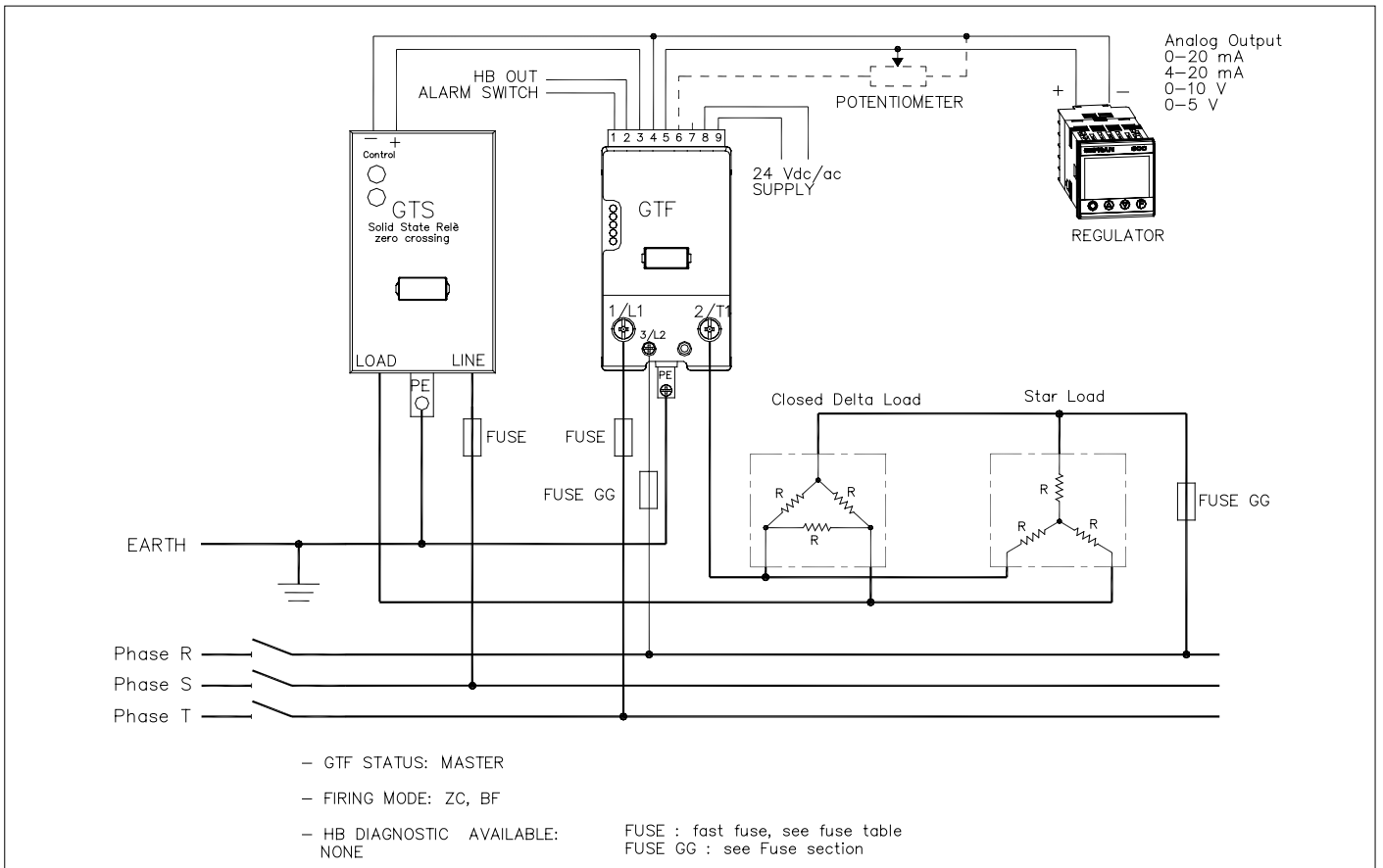

Connection example GTF 25-120A (with N. 3 GTF) for 3-phase star load with neutral

Figure 33

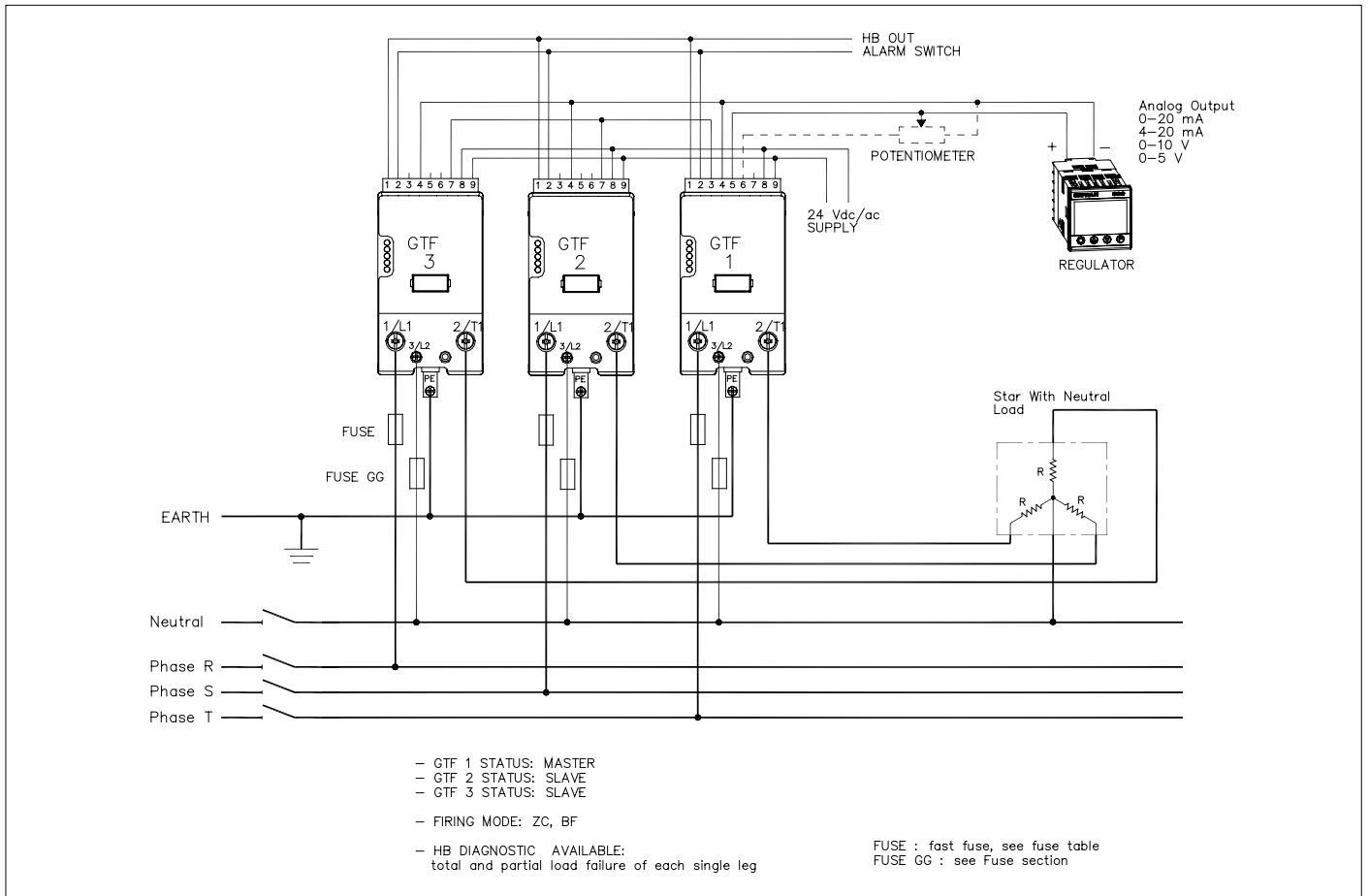

Connection example GTF 150-250A (with N. 3 GTF) for 3-phase star load with neutral

Figure 34

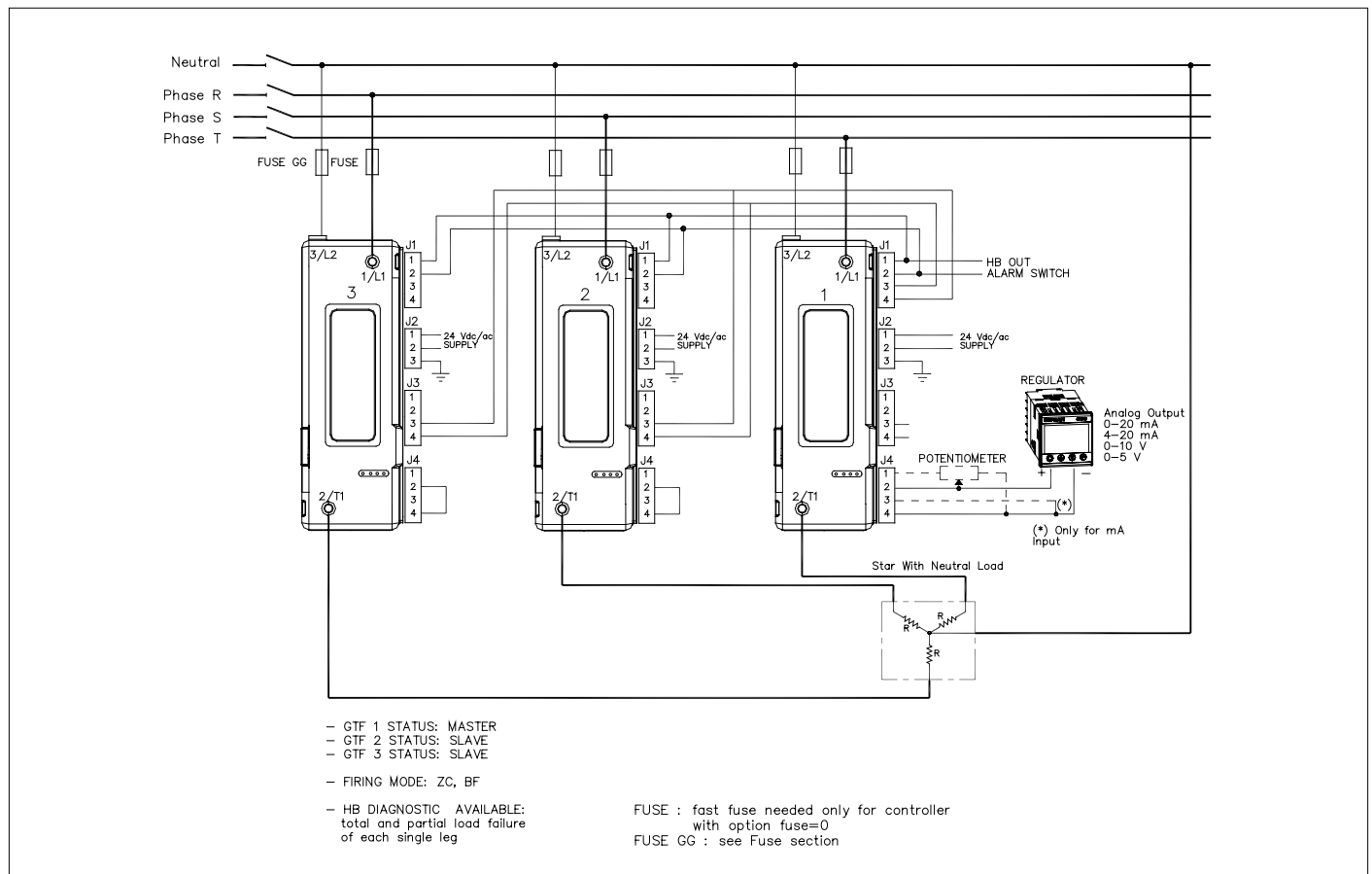

Connection example GTF 25-120A (Master with 2 Slave GTS) for 3-phase star load

Figure 35

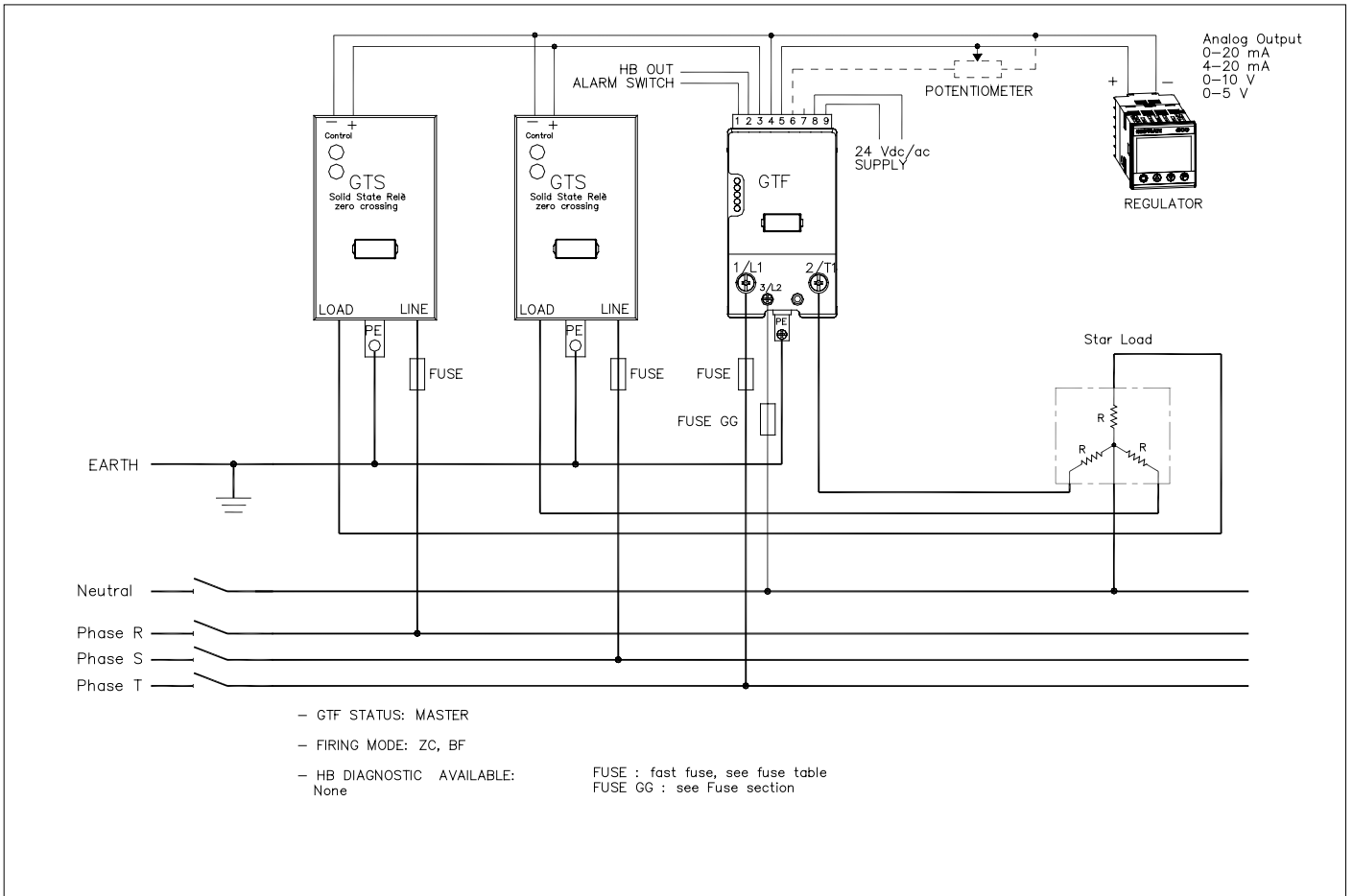



NOTES: USE WITH INDUCTIVE LOADS AND TRANSFORMERS

- a) Connect a varistor (MOV) between each wire of the primary transformer and ground.
Varistor data: rated voltage 660Vrms, ..., 1000Vrms; minimum energy 100J
- b) The maximum current controllable by the device is less than the product's rated value (see technical data).
- c) In ZC and BF trigger mode, use the Delay-triggering function to limit peak magnetization current.
- d) In PA trigger mode, use the Softstart function.
- e) DO NOT use HSC trigger mode.
- f) DO NOT connect RC snubbers in parallel to the transformer primary.
- g) Select the inductive load using the Hd.1 parameter (ref. Software manual)

Trigger modes

The GTF has the following power control modes:

- modulation via variation of number of conduction cycles with zero crossing trigger.
- modulation via variation of phase angle.

Zero Crossing mode

This function eliminates EMC noise. This mode controls power on the load via a series of conduction ON and non conduction OFF cycles.

ZC - constant cycle time ($T_c \geq 1$ sec, settable from 1 to 200 sec)

Cycle time is divided into a series of conduction and non conduction cycles in proportion to the power value to be transferred to the load.

Figure 36

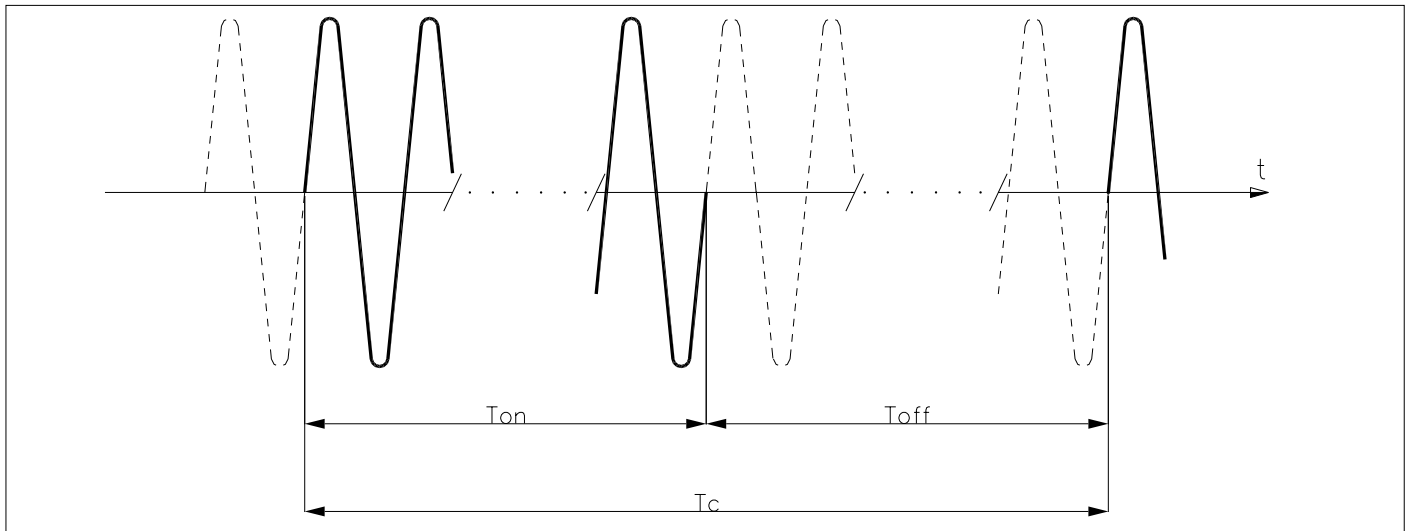

For example, if $T_c = 10$ sec, if the power value is 20% there is conduction for 2 sec (100 conduction cycles @ 50Hz) and non conduction for 8 sec (400 non conduction cycles @ 50Hz).

BF - variable cycle time (GTT)

This mode controls power on the load via a series of conduction ON and non conduction OFF cycles.

The ratio of the number of ON cycles to OFF cycles is proportional to the power value to be supplied to the load.

The CT repeat period is kept to a minimum for each power value (whereas in ZC mode the period is always fixed and not optimized).

Figure 37

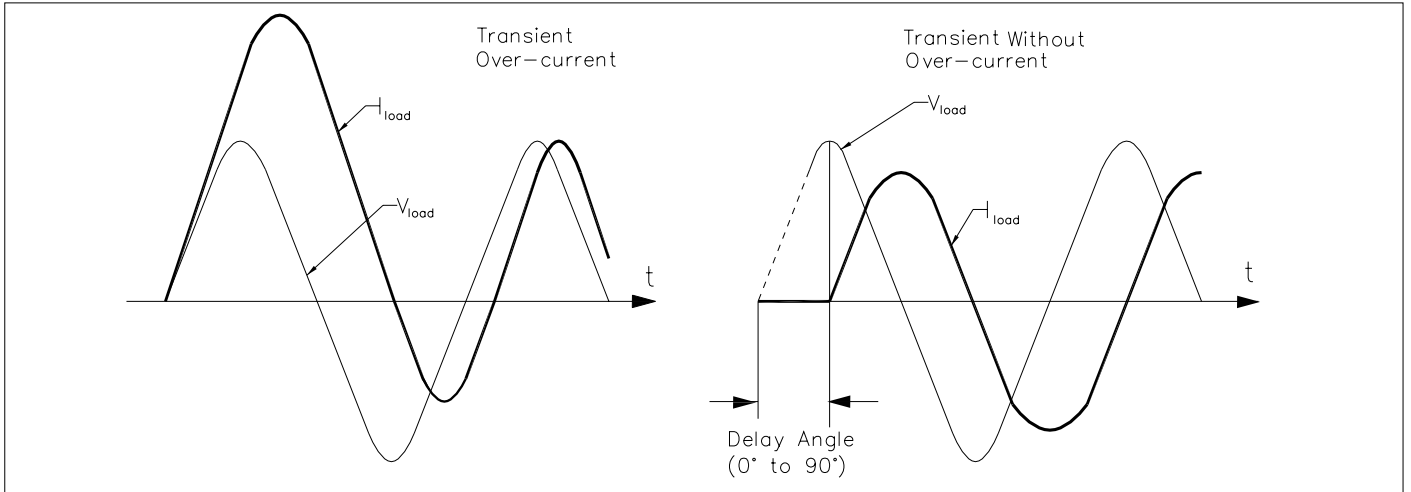

parameter defines the minimum number of conduction cycles settable from 1 to 10. In the following example, the parameter = 2.

HSC - Half single cycle



This mode corresponds to Burst Firing that manages ON and OFF half-cycles. It is useful for reducing the flickering of filaments with short/medium-wave IR lamp loads. With these loads, to limit operating current with low power, it is useful to set a minimum power limit (for example, $Lo.p = 10\%$).

NB: This mode is NOT allowed with inductive loads (transformers) It is used with resistive loads in single-phase, star with neutral, or open delta configuration.

Figure 38

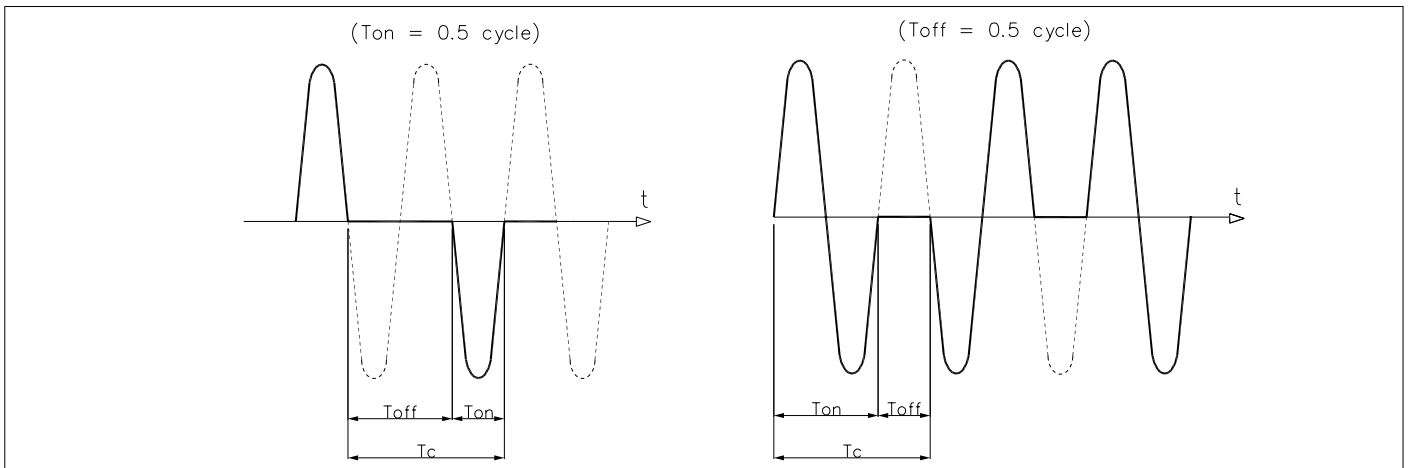

Example of operation in HSC mode with power at 33 and 66%.

Phase angle (PA)

This mode controls power on the load via modulation of trigger angle θ

Example: if power to be transferred to the load is 100%, $\theta = 180^\circ$
 or if power to be transferred to the load is 50%, $\theta = 90^\circ$

Figure 39

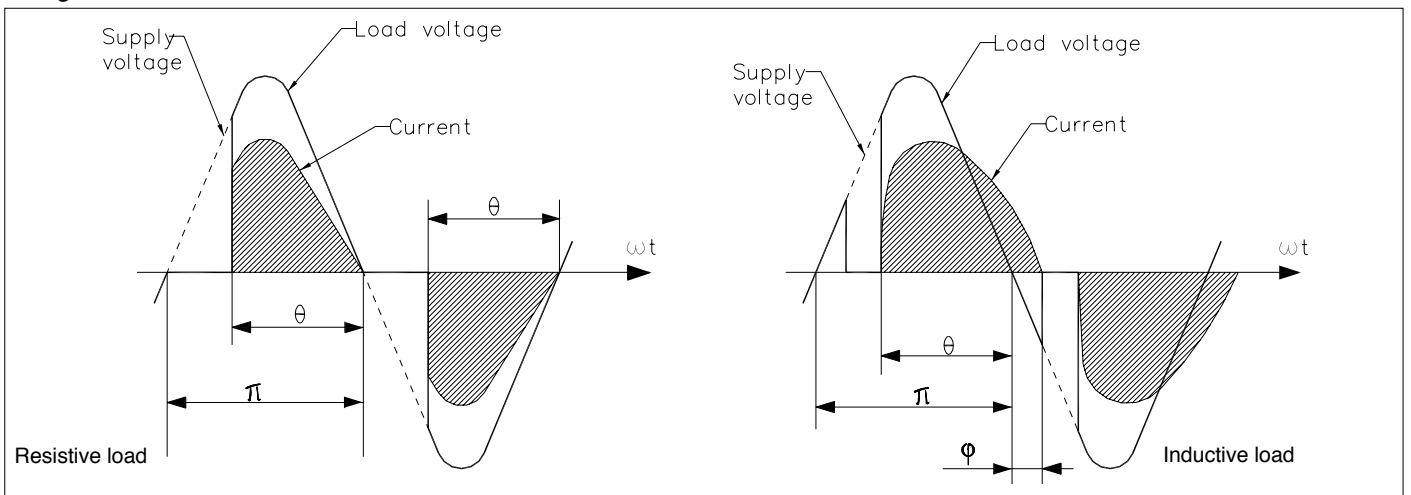

ADDITIONAL FUNCTIONS

Softstart

This type of start can be enabled either in phase control or pulse train mode and in zero-crossing mode (ZC, BF, HSC).

In phase control, the increment of conduction angle q stops at the corresponding value of the power to be transferred to the load.

Control of maximum peak current (useful in case of short circuit on the load or of loads with high temperature coefficients to automatically adjust start time to the load) can be enabled during softstart. When the load shut-off time (settable) is exceeded, the ramp is reactivated at the next power-on.

Figure 40

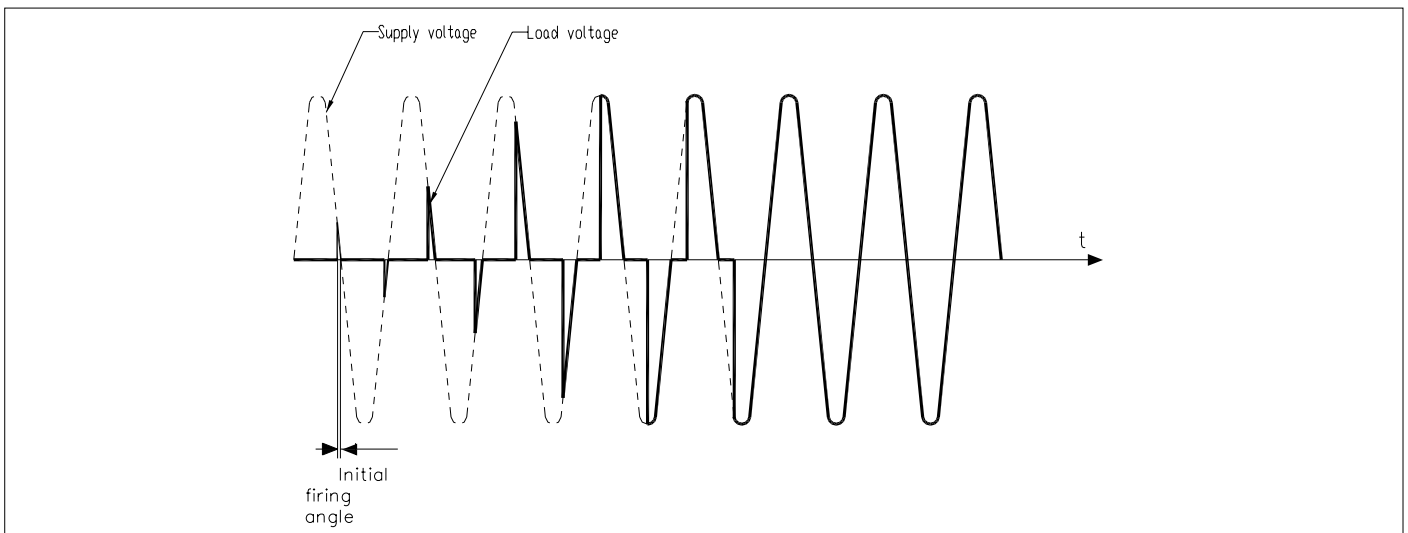

Example of firing ramp with phase Soft-Start

RMS current limit

The option for controlling the load current limit is available in all work modes.

If the current value exceeds the limit (settable in the nominal full-scale range) in mode PA the conduction angle is limited, while in zero-crossing mode (ZC, BF, HSC) the cycle time conduction percentage is limited. This limitation ensures that the RMS value (i.e., not the instantaneous value) of the load current does NOT exceed the set RMS current limit.

Figure 41

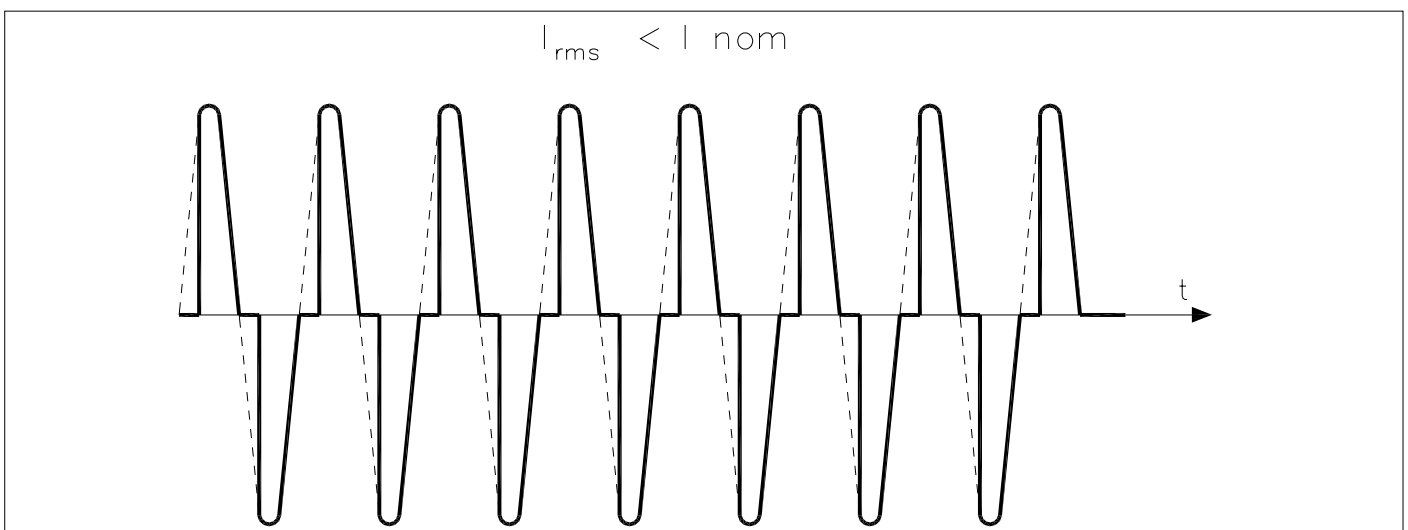

Example of conduction angle limitation in PA mode to respect an RMS current limit below the nominal current of the load.

DT - "Delay triggering" (for ZC, BF control modes only)

Settable from 0° to 90° .

Useful for inductive loads (transformer primaries) to prevent current peak that in certain cases could trip the high-speed fuses that protect the SCRs.

Figure 42

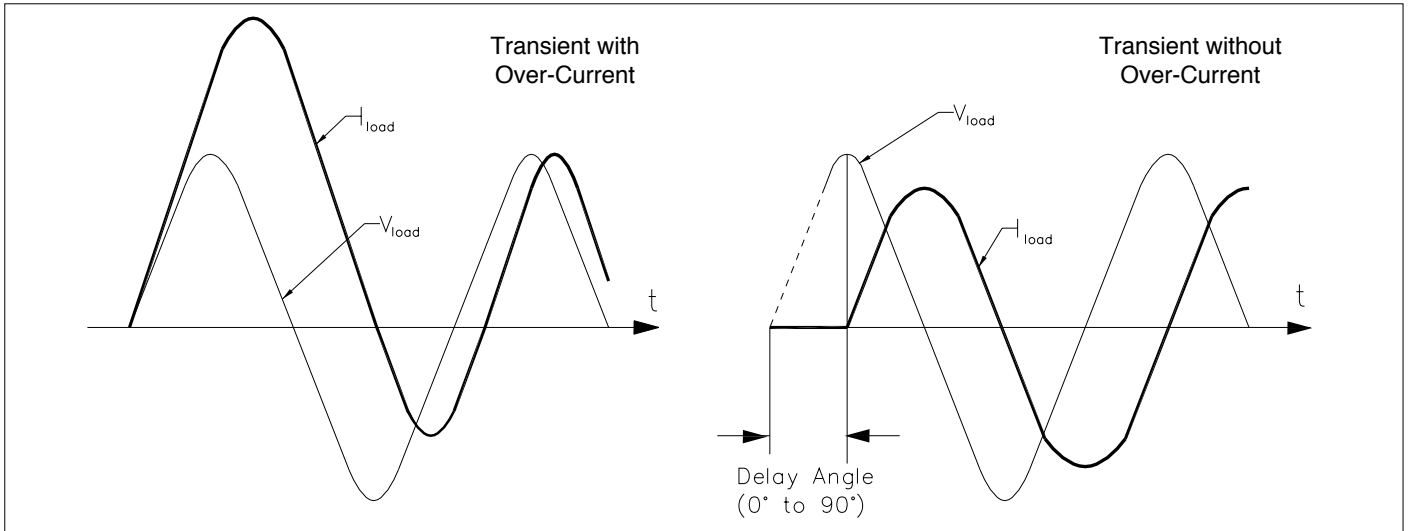

Example of firing of inductive load with/without delay-triggering.

To conduct inductive loads controlled in PA mode, do not use delay triggering; instead, use the phase Soft-Start ramp.

Figure 43

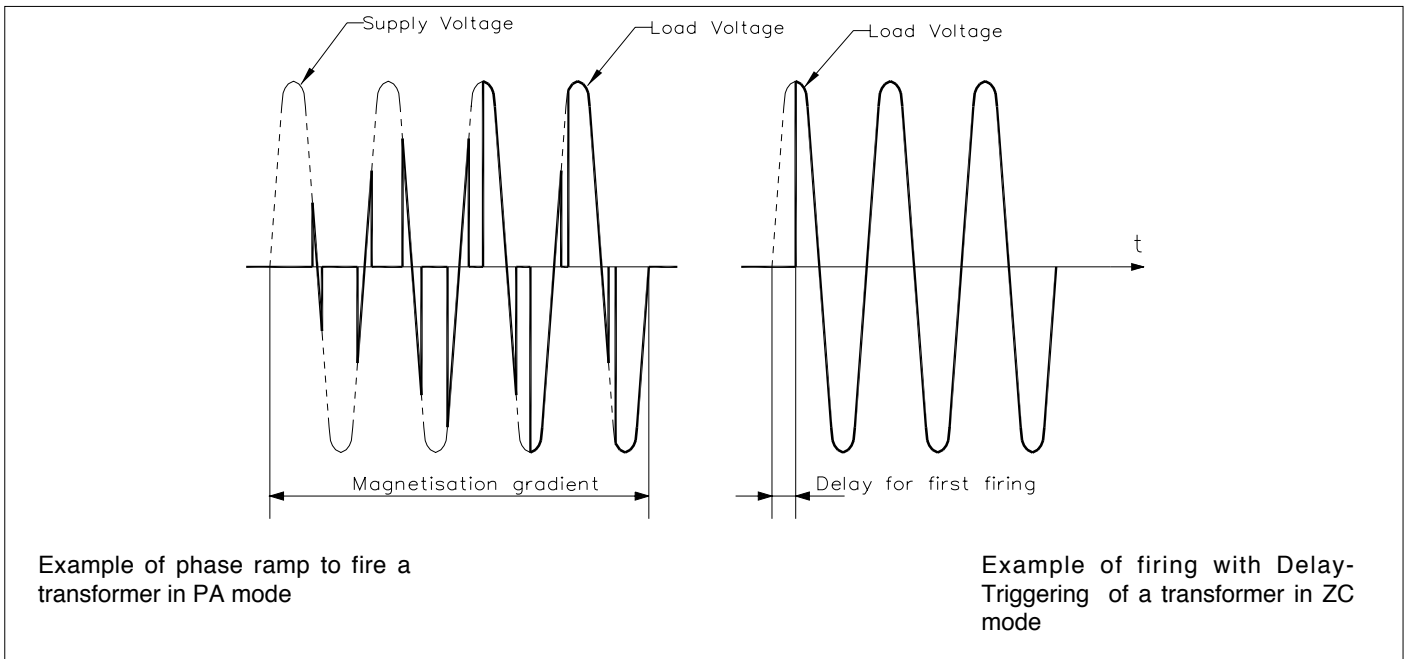

Comparison of method to fire a transformer: Soft-Start Ramp (for PA mode) / Delay triggering (for ZC and BF mode)

3.10 DIGITAL INPUT (PWM)

This digital input can be used to receive information on the % of power to be supplied to the load. The signal can be generated by a controller or external plc via digital outputs (logic output for Gefran instrumentation). This is obtained by alternating the output in ON for time TON with the output in OFF for time TOFF. The sum of TON+TOFF is constant, and is called CycleTime.

CycleTime= TON+TOFF

The power level is given by the ratio = TON/ CycleTime and is normally expressed in %.

The GTF digital input automatically adapts to the cycle time from 0.03Hz to 100Hz and obtains the power % to be supplied to the load from the TON/(TON+TOFF) ratio.

Connection example:

Temperature control with Gefran 600 with D type logic output (out2) (cycle time: 0.1 sec), logic output can drive max 3 GTF in series (preferable), connection allowed only if GTFs do not have interconnected GNDs (if so, make parallel connection).

To use Digital PWM the GTF can be ordered with the configuration **5 -x - M** or must be configured with the parameter dIG (digital input) = 7 (see Fig. 46, 47).

Figure 46

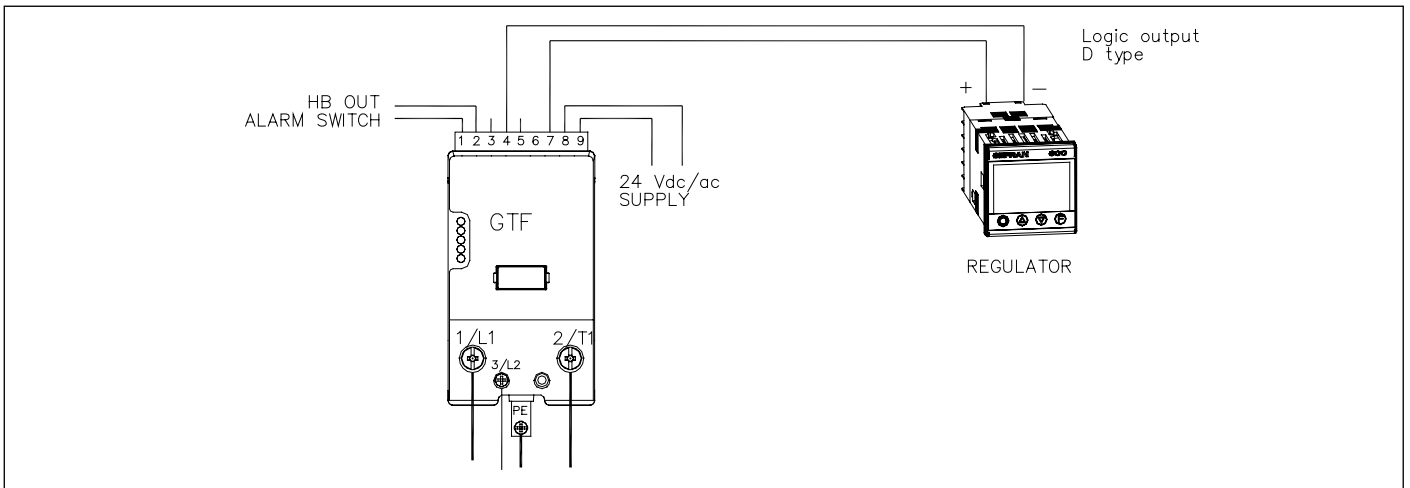
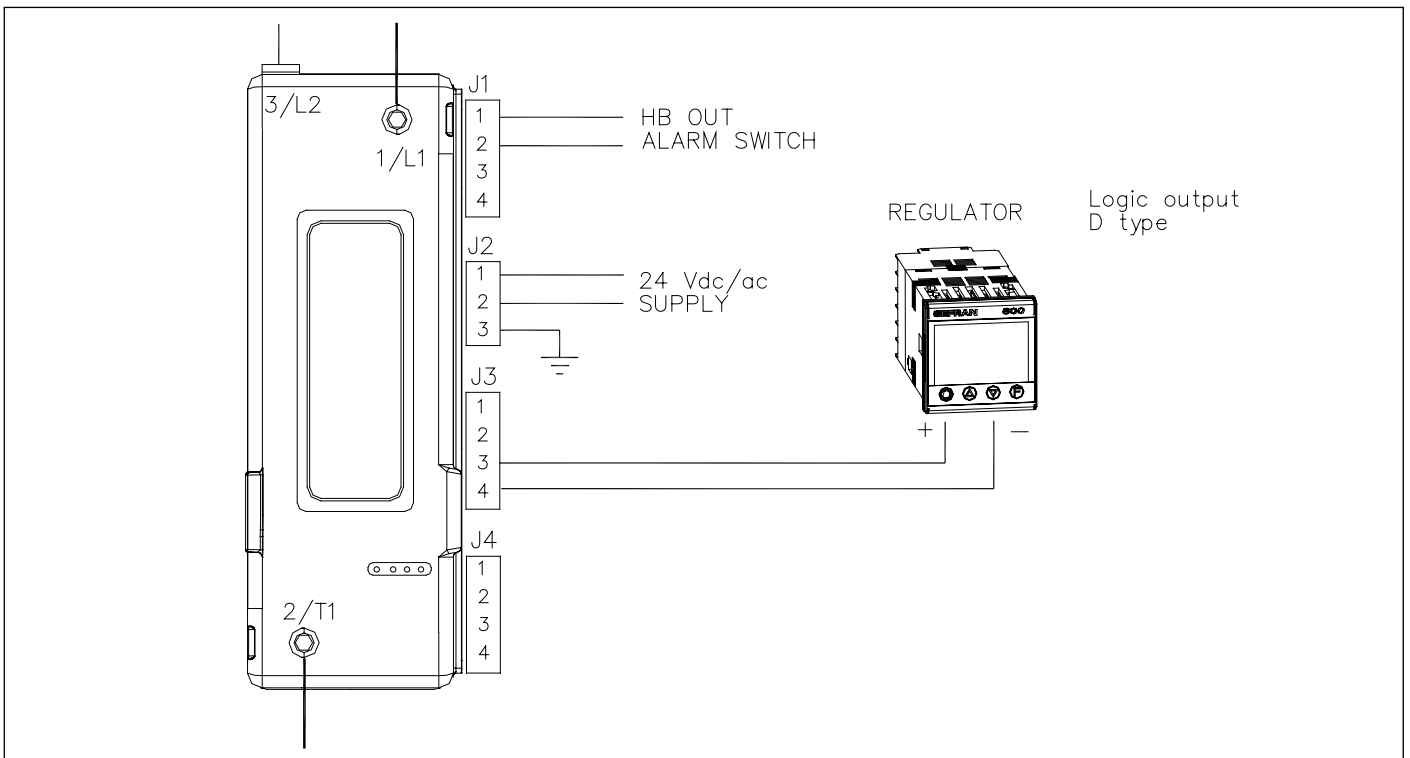

Figure 47



4 • INSTALLATION OF THE SERIAL PORT

A network typically has a Master that “manages” communication by means of “commands,” and Slaves that carry out these commands.

GTF modules are considered Slaves to the network master, which is usually a supervision terminal or a PLC.

It is positively identified by means of a node address (ID) set on rotary switches (tens + units).

A maximum of 99 GTF, modules can be installed in a serial network, with node address selectable from “01” to “99”

GTF modules have a ModBus serial (Optional)

The MODBUS RTU port 1 has the following factory settings (default):

Parameter	Default	Range
ID	1	1...99
BaudRate	19,2Kbit/s	1200...19200bit/s
Parity	None	Odd/Even/None
StopBits	1	-
DataBits	8	-

The following procedures are indispensable for the Modbus protocol.

Set the rotary switch at “0+0” for AutoBaud function

Parameter	Position rotary switches		
	tens	unit	
AutoBaud	0	0	Allows setting of the correct BaudRate value automatically detecting the master transmission frequency

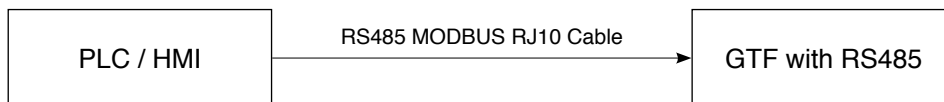

NOTE

The standard products DO NOT feature the communication RS485 Modbus serial port, but can be configured via PC with Gefran GF-Express Software, by connecting it to TTL port of GTF to PC, by means of TTL cable equipped with SW.

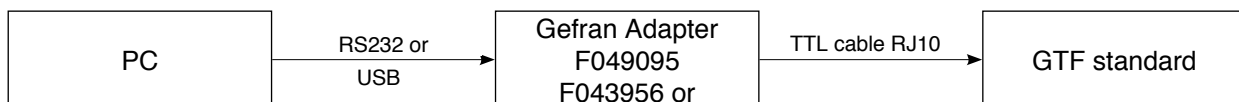

NEVER connect TTL adaptor to RS485 serial port of GTF.
NEVER connect TTL connector or GTF to a RS485 serial web .
Danger of product damage!!

Function

Adapt the serial communication speed and parity of the GTF modules to the connected supervision terminal or PLC.

 The "RUN" and "STATUS" LEDs mentioned in the procedure can vary its behavior based on the parameters Ld.1 e Ld.2

Procedure

- 1) Connect the serial cables for all modules on the network and to the supervision terminal.
- 2) Set the rotary switch on the GTF modules to be installed, or on all modules present in case of first installation, to position "0+0".
- 3) Check that the "RUN" and "STATUS" LEDs flash at high frequency (10Hz).
- 4) The supervision terminal must transmit a series of generic "MODBUS" read messages to the network.
- 5) The procedure is over when all of the "RUN" and "STATUS" LEDs on the GTF modules flash at a normal frequency (2Hz) (if parameter 50 Ld.1 = 16 as default).

The new speed parameter is saved permanently in each GTF; therefore, the "AUTOBAUD SERIAL" sequence does not have to be run at subsequent power-ups.

 When the rotary switch is turned, the green "STATUS" LED stays on steadily for about 6 seconds, after which it resumes normal operation and saves the address.

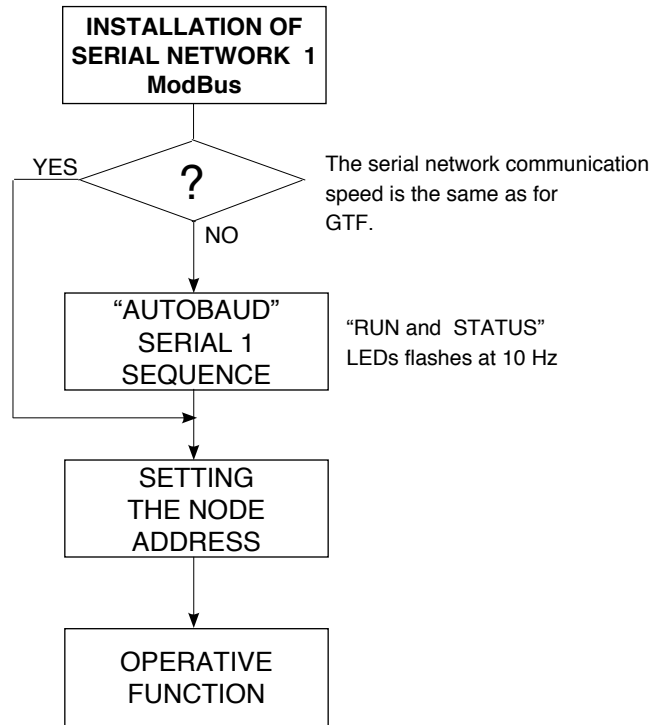

5 · TECHNICAL CHARACTERISTICS

INPUTS	
IN1 Analogic control inputs	
Function	Acquisition of control power
Max. error	1% f.s. +/- 1 scale point at ambient temperature of 25°C
Thermal drift	< 100 ppm/°C of f.s.
Sampling time	60 ms
Scale 0 -10V	Input impedance > 40 Kohms
Scale 0-5V	Input impedance > 40 Kohms
Scale 0-20mA or 4-20mA	Internal Shunt resistance: 125 ohm
Potentiometer input	Potentiometer resistance: from 1 Kohm to 47 Kohm Potentiometer supply: +5V (supplied by GTF, max 10mA)
Linear input read scale	0 100.0 %
INDIG Digital Input	
Function	Power Disable input or PWM input
Voltage range	5-30V (max 7 mA)
State "0" read safe voltage	< 2 V
State "1" read safe voltage	> 5V
PWM input	Maximum frequency: (0.03Hz, ..., 100 Hz) maximum resolution 1% (0.1ms)
Measures voltage and line current	
Function measures the load current	Measures RMS voltage by integral calculation of sampled values Meas. range: 0 ... 2 * rated_product
Accuracy RMS current measurement	3 % f.s. at room temperature of 25°C In PA mode with conduction angle >90° : 5% fs Thermal drift: < 200 ppm/°C
RMS line current measurement function	RMS voltage meas. by integral calculation of sampled values Work voltage range: 90...600Vac
Accuracy RMS voltage measurement	1 % f.s. at room temperature of 25°C Thermal drift: < 100 ppm/°C
Sampling time current/voltage	0,25 ms
Line frequency	50 / 60 Hz
OUTPUTS	
CONTROL OUTPUT MASTER/SLAVE	
Function	Control for synchronising another GTF or GTS slave (4 slave max.) Voltage: 7.5V , max 25 mA
HB ALARM OUTPUT (Optional)	
Function	HB alarm output or of other configurable alarms
Type	Solid state relay (MOS opto) Isolated contact, normally open Imax: 150mA Vmax. 30 Vac / Vdc Closing resistance < 15 ohm
COMMUNICATIONS PORTS	
RS485 Modbus (Optional)	
Function	Local serial communication
Protocol	ModBus RTU
Baudrate	Settable 1200 ... 19200 bit/s (default 19,2Kbit/s)
Node address	Settable with two rotary-switches (rotary-switches)
Type	RS485 - double connector RJ10 telephone type 4-4
Isolation	500V
TTL serial connector (Standard)	
Function	For product initial configuration only, via PC. Use a PC connected to GTF, ONLY via Gefran adapter Code F049095 (PC with USB) or Code F043957 (PC with RS232)
Isolation	TTL serial NOT isolated of CPU

POWER (SOLID-STATE)										
CATEGORY OF USE (Tab. 2 EN60947-4-3)	AC 51 resistive or low inductance loads AC 55b infrared lamps AC 56a: transformer									
Trigger mode	PA - Load management by adjusting the firing angle (only configuration single-phase or delta open) ZC - Zero Crossing with constant cycle time (settable in range 1-200sec) BF - Burst Firing with variable cycle time (GTT) optimized minimum. HSC - Half Single Cycle corresponds to Burst Firing that includes ON and OFF half-cycles. Useful for reducing flicker with short-wave IR loads (applied only to single-phase resistive or 3-phase 6-wire open delta loads).									
Feedback mode	V, V2: Voltage feedback proportional to RMS voltage value on load (useful to compensate possible variations in line voltage). I, I2: Current feedback: bound to RMS current value on load to compensate variations in line voltage and/or variations in load impedance. P: Power feedback: proportional to real power value on load (useful to keep constant values of electrical power assigned regardless of load impedance or line voltage variations).									
Max rated voltage	480Vac	600Vac	690Vac							
Work voltage range	90...530Vac	90...660Vac	90...760Vac							
Non-repetitive voltage	1200Vp	1600Vp	1600Vp							
Rated frequency	50/60Hz auto-determination									
Rated current AC51 -AC55b non-inductive or slightly inductive loads, IR lamps (@ Tamb = 40°C)	MODEL GTF									
	25	40	50	60	75	90	120	150	200	250
	25A	40A	50A	60A	75A	90A	120A	150A	200A	250A
Rated current AC56A permitted trigger modes: ZC, BF con DT (Delay Triggering),PA with softstart (@ Tamb =40 °C)	20A	32A	40A	50A	60A	75A	100A	125A	160A	200A
Non-repetitive overcurrent (t=10msec)	400A	520A	520A	1150A	1150A	1500A	1500A	5000A	8000A	8000A
I _q t for melting (t=1...10msec) A ² s	450	1800	1800	6600	6600	11200	11200	125000	320000	320000
Critical Dv/dt with output deactivated	1000V/μsec									
Held nominal voltage of on the impulse	4KV									
Nominal current for short circuit condition	5KA									
FUNCTION										
Diagnostics	Detection of short load circuit absence line voltage, HB alarm (partial breakage of load)									
OPTIONS										
Options	<ul style="list-style-type: none"> - Timed Soft-Start firing ramp, with or without peak current control - Soft-Start firing ramp, specific for infrared lamps - Timed shut-off ramp - Limitation of RMS current in load - 0-90° Delay-Triggering for firing inductive loads in ZC and BF mode 									
Diagnostic	<ul style="list-style-type: none"> - SCR in short circuit (presence of current with OFF control) - Absence of SCR current when under load. - Overtemperature alarm Current read <ul style="list-style-type: none"> • HB alarm interrupted or partially interrupted load • Automatic calibration of HB alarm setpoint starting from current value in load • Alarm for load in short circuit or overcurrent Voltage read <ul style="list-style-type: none"> • No line voltage 									
GENERAL DATA										
Power supply	GTF 25-120A: 24 Vac 50-60 Hz / Vdc ± 25%, max 3VA GTF 150-250A: 24 Vac 50-60 Hz / Vdc ± 25%, max 11VA									
Power supply external fan (only for GTF120A model)	24 Vdc ± 10%, max 200mA									
Signals	5 leds: RUN: run state of CPU STATUS: operating state ALARM: state of alarm output DIGITAL INPUT: state of digital inputs ON / OVER-TEMP.: state control thyristor / Alarm for overheating									
Load type and connection	Single phase load Independent single-phase load in open delta 3-phase load 3-phase load (star without neutral or closed triangle) with bi-phase control									

GENERAL DATA	
Protection	IP20
Work/storage temperature	0...40°C (refer to dissipation curves) / -20 °C - +70 °C average temperature over a period of 12:0 am not exceeding 35° C (according to EN 60947-4-3 § 7.1.1)
Relative humidity	20...85% RH non-condensing
Ambient conditions for use	indoor use, altitude up to 2000m
Installation	DIN bar EN50022 or panel with screws
Installation requirements	Installation category II, pollution level 2, double isolation (only for model >120A): - Max. temperature of air surrounding device 40°C; for temperature >40°C refer at derating curves - Device type: "UL Open Type"
Weight	
GTF 25, 40A	0,81 Kg
GTF 50, 60A	0,97 Kg
GTF 75, 90A	1,3 Kg
GTF 120A	1,5 Kg
GTF 150, 200, 250A	Max 2,6 Kg

5.1 DERATING CURVES

Figure 48

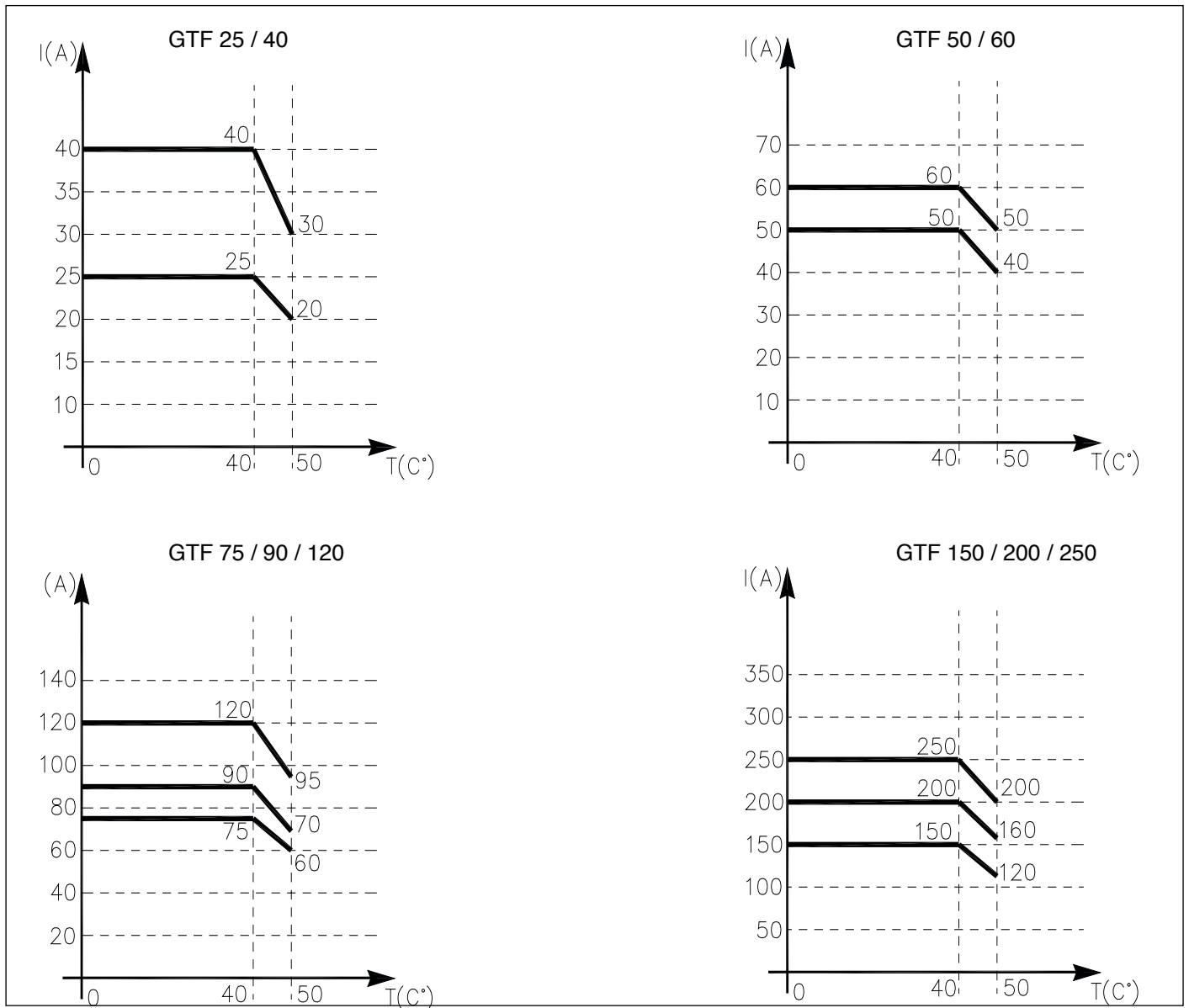

6 • TECHNICAL / COMMERCIAL INFORMATION



This section contains information on order codes for the Controller and its main accessories.

immediately identifies the unit's hardware configuration. Therefore, you must always give the order code when contacting Gefran Customer Care for the solution to any problems.

As mentioned in the Preliminary Instructions in this User Manual, a correct reading of the Controller order code

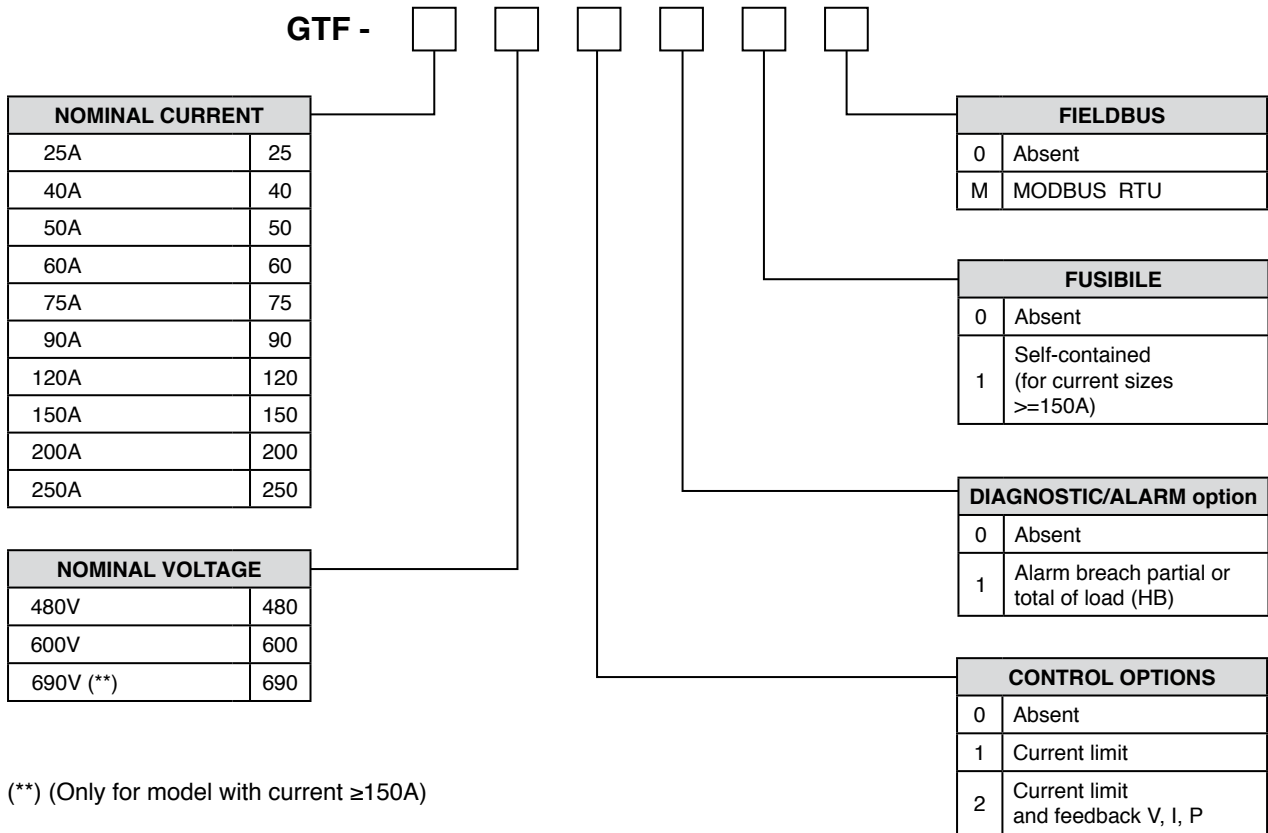

(**) (Only for model with current ≥150A)

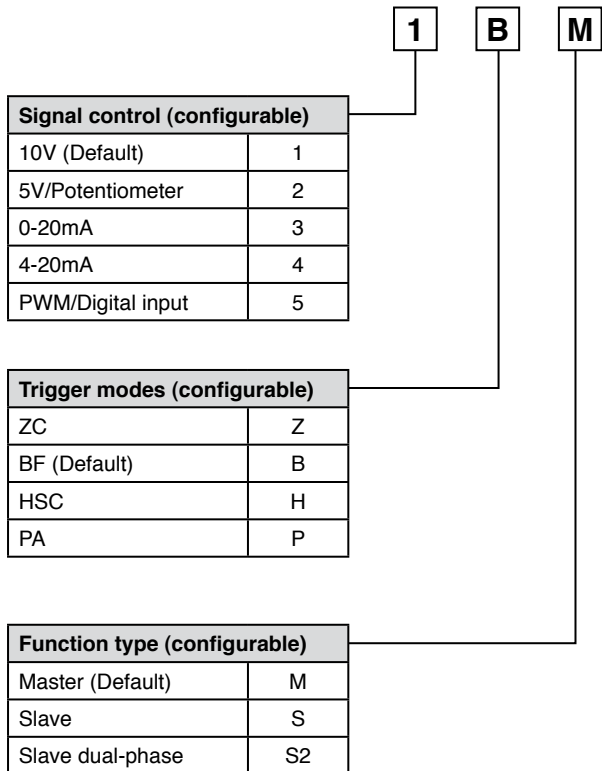

CONFIGURATION KIT



kit for PC via the USB port (Windows environment) for GTF standard configuration (TTL port) for configuration of GTF with the RS485 option

Lets you read or write all of the parameters of a single GTF

A single software for all models

- Easy and rapid configuration
- Saving and management of parameter recipes
- On-line trend and saving of historical data

Component Kit:

- Connection cable PC USB <----> GTF port TTL
- Connection cable PC USB <----> GTF RS485 port
- Serial line converter
- CD SW GF Express installation

ORDERING CODE

GF_eXK-2-0-0.....Cod. F049095

6.2 FUSE / FUSEHOLDERS

Model	EXTRARAPID FUSES				FUSEHOLDERS
	Size I ² t	Sign Form	Model Code	Power dissipation @ In	Adoption Acronym Code
GTF 25	25A 390A ² s	FUS-025 10x38	FWC25A10F 338474	6W	PFI-10X38 337134 UR30A@690V
GTF 40... GTF 50...	50A 1600A ² s	FUS-050 22x58	FWP50A22F 338127	9W	PFI-22X58 337223 UR80A@600V
GTF 60...	63A 3080A ² s	FUS-063 22x58	FWP63A22F 338191	11W	PFI-22X58 337223 UR80A@600V
GTF 75...	80A 6600A ² s	FUS-080 22x58	FWP80A22F 338199	14W	PFI-22X58 337223 UR80A@600V
GTF 90...	125A 6950A ² s	FUS-125N	660RF00AT125 338106	25W	PF-DIN 337092 UR400A@1000V
GTF 120...	125A 6950A ² s	FUS-125N	660RF00AT125 338106	25W	PF-DIN 337092 UR400A@1000V
GTF 150...	200A 31500A ² s	FUS-200S	DN000UB69V200 338930	19W	
GTF 200/250 480V/600V	450A 196000A ² s	FUS-450S	DN00UB60V450L 338932	17W	
GTF 200/250 690V	400A 150000A ² s	FUS-400S	DN00UB69V400L 338936	20W	

EXTRARAPID FUSE FOR GTS WHEN USED AS A SLAVE OF GTF

Model	Fuse Model size
GTS-T 10/230	FWC10A10F 10x38
GTS 15/230, GTS 15/480	FWC16A10F 10x38
GTS 25/480, GTS-T 20/230, GTS-T 25/230	FWC25A10F 10x38
GTS 40/230, GTS 40/480	FWP40A14F 14x51
GTS 50/230, GTS 50/480	FWP63A22F 22x58
GTS 60/230, GTS 60/480, GTS 75/230, GTS 75/480	FWP80A22F 22x58
GTS 90/230, GTS 90/480	FWP100A22F 22x58
GTS 120/230, GTS 120/480	170M1418 000-TN/80

6.2.1 Fuse GG

The electric protection device called FUSE GG must be done in order to grant the protection against the electric cable short circuit (see EN60439-1, par. 7.5 "Short-circuit protection and short-circuit with stand strength" and 7.6 "Switching devices and components installed in assemblies", otherwise the equivalent EN61439-1 paragraphs)